**Small-bore connectors for liquids and
gases in healthcare applications —**

Part 7:

**Connectors for intravascular or
hypodermic applications**

*Raccords de petite taille pour liquides et gaz utilisés dans le domaine
de la santé —*

*Partie 7: Raccords à 6 % (Luer) destinés aux applications
intravasculaires ou hypodermiques*



COPYRIGHT PROTECTED DOCUMENT

© ISO 2016, Published in Switzerland

All rights reserved. Unless otherwise specified, no part of this publication may be reproduced or utilized otherwise in any form or by any means, electronic or mechanical, including photocopying, or posting on the internet or an intranet, without prior written permission. Permission can be requested from either ISO at the address below or ISO's member body in the country of the requester.

ISO copyright office
Ch. de Blandonnet 8 • CP 401
CH-1214 Vernier, Geneva, Switzerland
Tel. +41 22 749 01 11
Fax +41 22 749 09 47
copyright@iso.org
www.iso.org

Contents

Page

Foreword	iv
Introduction	vi
1 * Scope	1
2 Normative references	1
3 Terms and definitions	2
4 General requirements	3
4.1 General requirements for LUER CONNECTORS.....	3
4.2 Material used for LUER CONNECTORS.....	4
4.3 Type tests.....	4
5 * Dimensional requirements for LUER CONNECTORS	4
6 Performance requirements	4
6.1 Fluid leakage.....	4
6.1.1 Fluid leakage requirement.....	4
6.1.2 Leakage by pressure decay.....	4
6.1.3 Positive pressure liquid leakage.....	5
6.2 Sub-atmospheric pressure air leakage.....	5
6.3 Stress cracking.....	5
6.4 Resistance to separation from axial load.....	5
6.5 Resistance to separation from unscrewing.....	5
6.6 Resistance to overriding.....	5
Annex A (informative) Rationale and guidance	7
Annex B (normative) LUER CONNECTORS	11
Annex C (normative) Reference CONNECTORS	22
Annex D (informative) Assessment of MEDICAL DEVICES and their attributes with CONNECTIONS within this APPLICATION	29
Annex E (informative) Summary of the usability requirements for LUER CONNECTORS for intravascular or hypodermic APPLICATIONS	31
Annex F (informative) Summary of LUER CONNECTOR design requirements for intravascular or hypodermic APPLICATIONS	35
Annex G (informative) Summary of assessment of the design of the LUER CONNECTOR for intravascular or hypodermic APPLICATIONS	38
Annex H (informative) Reference to the essential principles	41
Annex I (informative) Terminology — Alphabetized index of defined terms	42
Bibliography	43

Foreword

ISO (the International Organization for Standardization) is a worldwide federation of national standards bodies (ISO member bodies). The work of preparing International Standards is normally carried out through ISO technical committees. Each member body interested in a subject for which a technical committee has been established has the right to be represented on that committee. International organizations, governmental and non-governmental, in liaison with ISO, also take part in the work. ISO collaborates closely with the International Electrotechnical Commission (IEC) on all matters of electrotechnical standardization.

The procedures used to develop this document and those intended for its further maintenance are described in the ISO/IEC Directives, Part 1. In particular the different approval criteria needed for the different types of ISO documents should be noted. This document was drafted in accordance with the editorial rules of the ISO/IEC Directives, Part 2 (see www.iso.org/directives).

Attention is drawn to the possibility that some of the elements of this document may be the subject of patent rights. ISO shall not be held responsible for identifying any or all such patent rights. Details of any patent rights identified during the development of the document will be in the Introduction and/or on the ISO list of patent declarations received (see www.iso.org/patents).

Any trade name used in this document is information given for the convenience of users and does not constitute an endorsement.

For an explanation on the meaning of ISO specific terms and expressions related to conformity assessment, as well as information about ISO's adherence to the WTO principles in the Technical Barriers to Trade (TBT), see the following URL: [Foreword — Supplementary information](#).

The committee responsible for this document is ISO/TC 210, *Quality management and corresponding general aspects for medical devices*, and IEC/SC62D, *Electromedical equipment*. The draft was circulated for voting to the national bodies of both ISO and IEC.

This first edition of ISO 80369-7 cancels and replaces ISO 594-1:1986 and ISO 594-2:1998, clauses, subclauses, tables, figures, and annexes of which have been consolidated and technically revised.

This part of ISO 80369 contains the following major technical revisions to ISO 594-1 and ISO 594-2.

- a) New terms and definitions have been added to this part of ISO 80369 to more clearly define the various types of LUER CONNECTORS included in the scope of this part of ISO 80369. This part of ISO 80369 more broadly describes the requirements for the CONNECTORS used for intravascular or hypodermic APPLICATIONS, unlike ISO 594-1 and ISO 594-2 that are replaced by this part of ISO 80369, which only described the requirements for the fittings (intended CONNECTION surfaces) of these CONNECTORS. This distinction is important to define here because the previous International Standards do not contain the terms CONNECTOR or CONNECTION and ISO 80369- series does not use the term fitting.
- b) Requirements for certain dimensions not previously identified in ISO 594-1 and ISO 594-2 are added to this part of ISO 80369 to reduce the RISK of misconnections between MEDICAL DEVICES or ACCESSORIES for different APPLICATIONS with the SMALL-BORE CONNECTORS that are being developed under other parts of the ISO 80369- series. These new dimensions were selected to represent the current design and dimensions of LUER CONNECTORS in clinical use at the time this part of ISO 80369 was developed. The term "6 % (Luer) taper" used throughout the previous standards has also been clarified to the more commonly used equivalent specified diameters separated by a specified distance on a common axis.
- c) Requirements for gauging of LUER CONNECTORS made from SEMI-RIGID MATERIALS using plug and ring test gauges have been replaced by dimensional requirements, which are more precise and essential for reducing the RISK of misconnection with the other CONNECTORS identified in ISO 80369-1.

- d) Separate requirements for LUER CONNECTORS made from SEMI-RIGID MATERIALS and RIGID MATERIALS have been eliminated and combined as one common set of dimensions and requirements. This consolidation of requirements was made to further reduce the RISK of misconnection with other SMALL-BORE CONNECTORS.

ISO 80369 consists of the following parts, under the general title *Small-bore connectors for liquids and gases in healthcare applications*:

- *Part 1: General requirements*
- *Part 3: Connectors for enteral applications*
- *Part 5: Connectors for limb cuff inflation applications*
- *Part 6: Connectors for neuraxial applications*
- *Part 7: Connectors with 6 % (Luer) taper for intravascular or hypodermic applications*
- *Part 20: Common test methods*

Additional parts on connectors for urethral and urinary applications and for respiratory applications are planned.

Introduction

This part of ISO 80369 was developed because of several incidents, with catastrophic consequences, resulting from inappropriate medication, liquid nutritional formula or air being administered intravenously. Many incidents have been reported leading to international recognition of the importance of these issues and a need has been identified to develop specific CONNECTORS for MEDICAL DEVICES and their ACCESSORIES used to deliver fluids in other APPLICATIONS.

The ISO 80369- series was developed to prevent misconnection between SMALL-BORE CONNECTORS used in different APPLICATIONS. ISO 80369-1 specifies the requirements necessary to verify the designs and dimensions of SMALL-BORE CONNECTORS to ensure that

- a) they do not misconnect with other SMALL-BORE CONNECTORS, and
- b) they safely and securely connect with their mating half.

ISO 80369-20 contains the common TEST METHODS to support the performance requirements for SMALL-BORE CONNECTORS.

This part of ISO 80369 specifies the design and the dimensions and the drawings of SMALL-BORE CONNECTORS intended to be used as conical fittings with a 6 % (Luer) taper for CONNECTIONS in intravascular or hypodermic APPLICATIONS. [Annex D](#) to [Annex G](#) describe the methods by which this design has been assessed. Other parts of ISO 80369 include requirements for SMALL-BORE CONNECTORS used in different APPLICATION categories.

CONNECTORS manufactured to the dimensions set out within this part of ISO 80369 are dimensionally incompatible with any of the other CONNECTORS for APPLICATIONS identified in the ISO 80369- series of standards for SMALL-BORE CONNECTORS, except as indicated in [Annex G](#). If fitted to the relevant MEDICAL DEVICES and ACCESSORIES, these CONNECTORS should reduce the RISK of air, non-vascular medication and liquid nutritional formula being delivered through an alternative route, such as intravenously or through an airway device.

In this part of ISO 80369, the following print types are used:

- requirements and definitions: Roman type;
- informative material appearing outside of tables, such as notes, examples and references: in smaller type. Normative text of tables is also in a smaller type;
- terms defined in [Clause 3](#) or as noted: SMALL CAPITALS.

In this part of ISO 80369, the conjunctive “or” is used as an “inclusive or” so a statement is true if any combination of the conditions is true.

The verbal forms used in this part of ISO 80369 conform to usage described in the ISO/IEC Directives, Part 2, Annex H. For the purposes of this part of ISO 80369, the auxiliary verb:

- “shall” means that compliance with a requirement or a test is mandatory for compliance with this part of ISO 80369;
- “should” means that compliance with a requirement or a test is recommended but is not mandatory for compliance with this part of ISO 80369;
- “may” is used to describe a permissible way to achieve compliance with a requirement or test.

An asterisk (*) as the first character of a title or at the beginning of a paragraph or table title indicates that there is guidance or rationale related to that item in [Annex A](#).

Small-bore connectors for liquids and gases in healthcare applications —

Part 7:

Connectors for intravascular or hypodermic applications

1 * Scope

This part of ISO 80369 specifies dimensions and requirements for the design and functional performance of SMALL-BORE CONNECTORS intended to be used for CONNECTIONS in intravascular APPLICATIONS or hypodermic CONNECTIONS in hypodermic APPLICATIONS of MEDICAL DEVICES and ACCESSORIES.

EXAMPLES Hypodermic syringes and needles or intravascular (IV) cannulae with male and female LUER SLIP CONNECTORS and LUER LOCK CONNECTORS.

NOTE 1 Hypodermic use includes percutaneous infusion and injection as well as pressurizing and depressurizing the retention mechanisms (e.g. balloon) used to hold invasive medical devices in place and endoscopic devices.

NOTE 2 The LUER CONNECTOR was originally designed for use at pressures up to 300 kPa.

This part of ISO 80369 does not specify requirements for the MEDICAL DEVICES or ACCESSORIES that use these CONNECTORS. Such requirements are given in particular International Standards for specific MEDICAL DEVICES or ACCESSORIES.

This part of ISO 80369 does not specify requirements for the following SMALL-BORE CONNECTORS, which are specified in other International Standards:

- haemodialyser, haemodiafilter and haemofilter blood compartment ports (ISO 8637 and applicable portion of ISO 8638 referencing blood compartment ports);
- haemodialysis, haemodiafiltration and haemofiltration equipment CONNECTORS (ISO 8637);
- infusion system closure piercing CONNECTORS (ISO 8536-4).

NOTE 3 MANUFACTURERS are encouraged to incorporate the SMALL-BORE CONNECTORS specified in this part of ISO 80369 into MEDICAL DEVICES or ACCESSORIES, even if currently not required by the relevant particular MEDICAL DEVICE standards. It is expected that when the relevant particular MEDICAL DEVICE standards are revised, requirements for SMALL-BORE CONNECTORS, as specified in ISO 80369, will be included.

NOTE 4 ISO 80369-1:2010, 5.8, specifies alternative methods of compliance with ISO 80369-1:2010, for SMALL-BORE CONNECTORS intended for use with intravascular APPLICATIONS or hypodermic APPLICATION MEDICAL DEVICES or ACCESSORIES, which do not comply with this part of ISO 80369.

2 Normative references

The following documents, in whole or in part, are normatively referenced in this document and are indispensable for its application. For dated references, only the edition cited applies. For undated references, the latest edition of the referenced document (including any amendments) applies.

ISO 14971:2007, *Medical devices — Application of risk management to medical devices*

ISO 80369-1:2010, *Small-bore connectors for liquids and gases in healthcare applications — Part 1: General requirements*

ISO 80369-7:2016(E)

ISO 80369-6:2016, *Small bore connectors for liquids and gases in healthcare applications — Part 6: Connectors for neuraxial applications*

ISO 80369-20:2015, *Small-bore connectors for liquids and gases in healthcare applications — Part 20: Common test methods*

ASTM D638-14, *Standard test method for tensile properties of plastics*

ASTM D790-15e2, *Standard test methods for flexural properties of unreinforced and reinforced plastics and electrical insulating materials*

3 Terms and definitions

For the purposes of this document, the terms and definitions specified in ISO 80369-1:2010, ISO 80369-20:2015, ISO 14971:2007 and the following apply.

NOTE For convenience, the sources of all defined terms used in this document are given in [Annex I](#).

3.1

* LUER CONNECTOR

SMALL-BORE CONNECTOR that contains a conical mating surface with a 6 % (Luer) taper intended for use in intravascular or hypodermic APPLICATIONS of MEDICAL DEVICES and related ACCESSORIES

Note 1 to entry: A LUER CONNECTOR can be either a LUER SLIP CONNECTOR or a LUER LOCK CONNECTOR.

3.2

* LUER SLIP CONNECTOR

LUER CONNECTOR without a lock

Note 1 to entry: The LUER SLIP CONNECTOR is indicated by the abbreviation L1.

3.3

* LUER LOCK CONNECTOR

LUER CONNECTOR that contains a locking mechanism

Note 1 to entry: The LUER LOCK CONNECTOR is indicated by the abbreviation L2.

3.4

NORMAL USE

operation, including routine inspection and adjustments by any USER, and stand-by, according to the instructions for use

Note 1 to entry: NORMAL USE should not be confused with INTENDED USE. While both include the concept of use as intended by the MANUFACTURER, INTENDED USE focuses on the medical purpose while NORMAL USE incorporates not only the medical purpose, but maintenance, service, transport, etc. as well.

[SOURCE: IEC 60601-1:2005+A1:2012, 3.71, modified — replaced “OPERATOR” with “USER”.]

3.5

RATED (value)

term referring to a value assigned by the MANUFACTURER for a specified operating condition

[SOURCE: IEC 60601-1:2005, 3.97]

3.6

USER

person interacting with (i.e. operating or handling) the MEDICAL DEVICE

Note 1 to entry: There can be more than one USER of a MEDICAL DEVICE.

Note 2 to entry: Common USERS include clinicians, PATIENTS, cleaners, maintenance and service personnel.

[SOURCE: IEC 62366-1:2015, 3.24]

3.7

USER PROFILE

summary of the mental, physical and demographic traits of an intended USER group, as well as any special characteristics, such as occupational skills and job requirements and working conditions, which can have a bearing on design decisions

[SOURCE: IEC 62366-1:2015, 3.29]

4 General requirements

4.1 General requirements for LUER CONNECTORS

LUER CONNECTORS made in compliance with this part of ISO 80369 comply with the general requirements of ISO 80369-1:2010, unless otherwise indicated in this part of ISO 80369.

In some tolerance combinations, the inside diameter of the fluid lumen of male LUER CONNECTOR may contact the sealing surfaces of the N1 male CONNECTOR (N1), as specified in ISO 80369-6, in LMC conditions and thereby these CONNECTORS mutually fail when evaluating the NON-INTERCONNECTABLE characteristics tests of ISO 80369-1:2010, Annex B. Additional information is provided in ISO 80369-1:2010, G.2.2.

Because the following CONNECTORS are inadequately specified, LUER CONNECTORS should not, but may connect with

- the cones and sockets of ISO 5356-1:2004, ISO 5356-1:2015, ISO 5356-2:2006, and ISO 5356-2:2012,
- the temperature sensor CONNECTORS and mating ports made in compliance with ISO 8185:2007, Annex DD, and
- the nipples of EN 13544-2:2002 and EN 13544-2:2002+Amd1:2009.

The reference CONNECTORS for evaluation of the NON-INTERCONNECTABLE characteristics are described in [Annex C](#).

Where the design of a LUER CONNECTOR of this part of ISO 80369 relies on dimensions or features of the MEDICAL DEVICE OR ACCESSORY to ensure NON-INTERCONNECTABLE characteristics, the NON-INTERCONNECTABLE characteristics shall be VERIFIED.

Check compliance by applying the tests of ISO 80369-1:2010, 5.1, and ISO 80369-1:2010, Annex B. Compliance may be shown by applying a computer aided design (CAD) analysis of the dimensions of all of the ISO 80369- series SMALL BORE CONNECTORS and the SMALL BORE CONNECTOR under test, in conjunction with physical testing of the SMALL BORE CONNECTOR per [Annex B](#) where the CAD analysis does not demonstrate the NON-INTERCONNECTABLE characteristics. When necessary, the SMALL-BORE CONNECTOR may be installed on the MEDICAL DEVICE OR ACCESSORY to demonstrate compliance with the NON-INTERCONNECTABLE characteristics test requirements of ISO 80369-1:2010, Annex B.

NOTE 1 MEDICAL DEVICES using the LUER CONNECTORS of this part of ISO 80369 that do not rely on the dimensions or features of the MEDICAL DEVICE OR ACCESSORY to ensure NON-INTERCONNECTABLE characteristics are presumed to comply with the NON-INTERCONNECTABLE characteristics test requirements of this part of ISO 80369.

NOTE 2 The summary of MEDICAL DEVICES and their attributes with CONNECTIONS within this APPLICATION is provided in [Annex D](#).

NOTE 3 The summary of the usability requirements for LUER CONNECTORS is provided in [Annex E](#).

NOTE 4 The summary of LUER CONNECTORS criteria and requirements is provided in [Annex E](#).

ISO 80369-7:2016(E)

NOTE 5 The summary of assessment of the design of LUER CONNECTORS according to ISO 80369-1:2010, Clause 7, is contained in [Annex G](#).

4.2 Material used for LUER CONNECTORS

In addition to the requirements of ISO 80369-1:2010, Clause 4, LUER CONNECTORS shall be made of materials with a nominal modulus of elasticity either in flexure or in tension greater than 700 MPa.

Check compliance by applying the tests of ASTM D638-14 or ASTM D790-15e2.

4.3 Type tests

Compliance with the requirements of this part of ISO 80369 shall be determined by TYPE TESTS.

5 * Dimensional requirements for LUER CONNECTORS

LUER CONNECTORS shall comply with the dimensions and tolerances as given in

- [Figure B.1](#) and [Table B.1](#) for a male LUER SLIP CONNECTOR (L1),
- [Figure B.2](#) and [Table B.2](#) for a female LUER SLIP CONNECTOR (L1),
- [Figure B.3](#) and [Table B.3](#) for a male LUER LOCK CONNECTOR (L2), with fixed collar,
- [Figure B.4](#) and [Table B.4](#) for a male LUER LOCK CONNECTOR (L2), with floating or rotatable collar,
- [Figure B.5](#) and [Table B.5](#) for a female LUER LOCK CONNECTOR (L2),
- [Figure B.6](#) and [Table B.6](#) for a female LUER LOCK CONNECTOR (L2), with lugs at right angle to axis, variant A,
- [Figure B.7](#) and [Table B.7](#) for a female LUER LOCK CONNECTOR (L2), with lugs at right angle to axis, variant B, and
- [Figure B.8](#) and [Table B.8](#) for a female LUER LOCK CONNECTOR (L2), with lugs at right angle to axis, variant C.

Check compliance by confirming the dimensions and tolerances specified in [Annex B](#), as appropriate.

6 Performance requirements

6.1 Fluid leakage

6.1.1 Fluid leakage requirement

LUER CONNECTORS shall be evaluated for leakage using either the leakage by pressure decay TEST METHOD or the positive pressure liquid leakage TEST METHOD.

6.1.2 Leakage by pressure decay

LUER CONNECTORS evaluated for fluid leakage performance with the leakage by pressure decay TEST METHOD shall not leak by more than 0,005 Pa·m³/s while being subjected to an applied pressure of between 300 kPa and 330 kPa over a hold period between 15 s and 20 s using air as the medium. MANUFACTURERS may use a greater applied pressure.

Check compliance by applying the tests of ISO 80369-20:2015, Annex B, while using the leakage reference CONNECTOR specified in [Annex C](#).

6.1.3 Positive pressure liquid leakage

LUER CONNECTORS evaluated for fluid leakage performance with the positive pressure liquid leakage TEST METHOD shall show no signs of leakage, sufficient to form a falling drop of water, over a hold period of 30 s to 35 s while being subjected to an applied pressure of between 300 kPa and 330 kPa. MANUFACTURERS may use a greater applied pressure.

Check compliance by applying the tests of ISO 80369-20:2015, Annex C, while using the leakage reference CONNECTOR specified in [Annex C](#).

6.2 Sub-atmospheric pressure air leakage

LUER CONNECTORS shall be evaluated for sub-atmospheric pressure air leakage. LUER CONNECTORS shall not leak by more than 0,005 Pa·m³/s while being subjected to an applied sub-atmospheric pressure of between 80,0 kPa and 88,0 kPa over a hold period of between 15 s and 20 s. MANUFACTURERS may use a greater applied sub-atmospheric pressure.

Check compliance by applying the tests of ISO 80369-20:2015, Annex D, while using the leakage reference CONNECTOR specified in [Annex C](#).

6.3 Stress cracking

LUER CONNECTORS shall be evaluated for stress cracking. LUER CONNECTORS shall meet the requirements of [6.1.1](#) after being subjected to stresses of ISO 80369-20:2015, Annex E.

Check compliance by applying the tests of ISO 80369-20:2015, Annex E, while using the stress cracking reference CONNECTOR specified in [Annex C](#).

6.4 Resistance to separation from axial load

LUER CONNECTORS shall be evaluated for separation from axial load. LUER CONNECTORS shall not separate from the reference CONNECTOR over a hold period between 10 s and 15 s while being subjected to a disconnection applied axial force between

- a) 23 N and 25 N for LUER SLIP CONNECTORS, and
- b) 32 N and 35 N for LUER LOCK CONNECTORS.

MANUFACTURERS may use a greater disconnection applied axial force or a longer hold period.

Check compliance by applying the tests of ISO 80369-20:2015, Annex F, while using the separation from axial load reference CONNECTOR specified in [Annex C](#).

6.5 Resistance to separation from unscrewing

LUER LOCK CONNECTORS shall be evaluated for separation from unscrewing. LUER LOCK CONNECTORS shall not separate from the reference CONNECTOR for a hold period between 10 s and 15 s while being subjected to an unscrewing torque of between 0,019 8 N·m to 0,020 0 N·m. MANUFACTURERS may use a greater applied unscrewing torque or a longer hold period.

Check compliance by applying the tests of ISO 80369-20:2015, Annex G, while using the resistance to separation from unscrewing reference CONNECTOR specified in [Annex C](#).

6.6 Resistance to overriding

LUER LOCK CONNECTORS shall be evaluated for resistance to overriding. LUER LOCK CONNECTORS shall not override the threads or lugs of the reference CONNECTOR while being subjected to an applied torque of between 0,15 N·m to 0,17 N·m over a hold period between 5 s and 10 s. MANUFACTURERS may use a greater applied torque or a longer hold period.

ISO 80369-7:2016(E)

Check compliance by applying the tests of ISO 80369-20:2015, Annex G, while using the resistance to overriding reference CONNECTOR specified in [Annex C](#).

Annex A (informative)

Rationale and guidance

A.1 General guidance

This Annex provides a rationale for some requirements of part of ISO 80369 and is intended for those who are familiar with the subject of part of ISO 80369 but who have not participated in its development. An understanding of the rationale underlying these requirements is considered to be essential for their proper use. Furthermore, as clinical practice and technology change, it is believed that a rationale will facilitate any revision of this part of ISO 80369 necessitated by those developments.

A.2 Rationale for particular clauses and subclauses

The clauses and subclauses in this Annex have been numbered to correspond to the numbering of the clauses and subclauses of this part of ISO 80369 to which they refer. The numbering is, therefore, not consecutive.

Clause 1 Scope

The scope includes the fittings described previously in ISO 594-1 and ISO 594-2.

In 2000, a Task Group of the European standards organization CEN proposed a strategy to reduce incidents of accidental misconnection of PATIENT therapy lines by the use of a series of NON-INTERCONNECTABLE CONNECTORS, differentiated by design, for use in different medical APPLICATIONS. The strategy reserves the use of LUER CONNECTORS solely for use in MEDICAL DEVICES used to access the vascular system or for hypodermic applications so that they can achieve their intended function^[13].

During the development of this part of ISO 80369, the committee frequently debated how LUER CONNECTOR activated MEDICAL DEVICES (LADs) should be interpreted. In context of this part of ISO 80369, "LADs" are considered to be a "component" of the MEDICAL DEVICE and are typically a female valve designed to interconnect with male LUER CONNECTOR. The following guidance relates specifically to the LAD (or female valve end) component only and does not include the rest of a MEDICAL DEVICE.

A LAD typically includes a valve that opens and permits access to the fluid conduit when a standard male LUER CONNECTOR is inserted into it. By design, it forms one-half of the CONNECTION that establishes a fluid conduit with a male LUER CONNECTOR. However, such LADs typically do not comply with this part of ISO 80369. Specifically, they often do not conform to [4.2](#) regarding materials (since their mating surfaces often include elastomeric materials) nor do they fully conform dimensionally to [Clause 5](#). Thus, a typical LAD is not a LUER CONNECTOR. As such, they are not within the scope of this part of ISO 80369.

The committee, however, felt compelled to provide some guidance on the LAD due to the obvious similarities of intended use with LUER CONNECTORS. It is advisable that MANUFACTURERS of LADs utilize the features providing NON-INTERCONNECTABLE characteristics of this part of ISO 80369, wherever possible, to address the RISK of misconnections to their MEDICAL DEVICES. These elements can include the appropriate combinations of the following:

- materials conformance (i.e. ≥ 700 MPa) for interference features;
- dimensional conformance (i.e. dimensions *H*, *J*, *D*, and *G* from [Annex B](#));
- dimensional and/or CAD analysis showing interference features;
- NON-INTERCONNECTABLE characteristics testing per ISO 80369-1:2010, Annex B;

ISO 80369-7:2016(E)

— usability testing demonstrating NON-INTERCONNECTABLE characteristics.

Additionally, the functional performance requirements of [Clause 6](#) should also be considered for the LAD component.

In this way, the LADs can be evaluated for both NON-INTERCONNECTABLE characteristics and performance characteristics associated with the ISO 80369- series.

The LADs by definition continue to not be considered a “conforming” LUER CONNECTOR (i.e. not complying with this part of ISO 80369), however they can be considered ‘compatible with’ a MEDICAL DEVICE utilizing a male LUER CONNECTOR (by way of functional performance).

MANUFACTURERS and RESPONSIBLE ORGANIZATIONS are encouraged to report their experience with the LUER CONNECTORS specified in this part of ISO 80369 to the Secretariat of ISO/TC 210, so that it can consider this feedback during the revision of the relevant part of the ISO 80369- series.

Definition 3.1 LUER CONNECTOR

Definition 3.2 LUER SLIP CONNECTOR

Definition 3.3 LUER LOCK CONNECTOR

For clarity, the new terms LUER CONNECTOR, LUER SLIP CONNECTOR, and LUER LOCK CONNECTOR replace conflicting and confusing terms used in ISO 594-1 and ISO 594-2. The new terms align and harmonize this part of ISO 80369 with ISO 80369-1, which does not utilize the legacy terms fitting, conical, or taper. The new terms are equivalent to those now generically used to describe the SMALL-BORE CONNECTORS commonly named after their inventor, 19th century German medical instrument maker Hermann Wülfig Lüer.

[Clause 5](#) Dimensional requirements for LUER CONNECTORS

The separate set of dimensions previously identified for SEMI-RIGID MATERIALS and RIGID MATERIALS are now merged into one set of dimensions. With modern test equipment and TEST METHODS, it is now practicable to define the dimensions with greater precision, thereby eliminating the need for gauging for the purposes of a TYPE TEST.

Legacy Luer gauges cannot be used to verify the performance of CONNECTORS that are intended to prevent misconnection because they lack the dimensions for surfaces not intended to form CONNECTIONS with LUER CONNECTORS. Maintenance of production quality (i.e. using gauges) is outside the scope of this part of ISO 80369. The dimensional requirements in [Annex B](#) are a more precise description of the design and performance characteristics for both intended CONNECTIONS and avoidance of misconnections.

Dimensions and tolerances not previously identified in ISO 594-1 and ISO 594-2 are added to this part of ISO 80369 to reduce the RISK of misconnections between MEDICAL DEVICES or between ACCESSORIES for different APPLICATIONS with non-LUER CONNECTORS that are being developed under other parts of the ISO 80369- series. These new requirements were selected to represent the inherent design and dimensions of LUER CONNECTORS in clinical use at the time this part of ISO 80369 was developed.

Since the configurations of the CONNECTORS proposed within ISO 80369-7 are SMALL-BORE CONNECTORS with or without a threaded collar, the requirements and parameters from ISO 594-1 and ISO 594-2 have been used where applicable.

The maximum inside diameter at the tip of the male taper (through bore), $\emptyset f$, of 2,900 mm was chosen to describe the majority of LUER CONNECTORS available to USERS at the time of publication of this part of ISO 80369. The committee considered the clinical needs of high flow rate intravascular MEDICAL DEVICES and determined that the incremental increase in flow if $\emptyset f$ is increased to a theoretical sharp edge of 3,50 mm was not warranted in view of the increased RISK of misconnection with smaller male SMALL-BORE CONNECTORS in the ISO 80369- series.

Commercially developed glass prefilled syringes routinely mate with LUER CONNECTOR equipped MEDICAL DEVICES in order to effectively administer the medication stored within the syringe. Examples: disposable needles, needleless ports and other forms of Luer access. Current state-of-technology syringe

tip glass forming technology for manufacturing glass-prefilled syringes cannot conform completely to either previous Luer fitting standard, ISO 594 or this part of ISO 80369. Both the previous standard and this part of ISO 80369 have been developed using ground glass, metal and injection moulded technology and plastic resins as the baseline for compliance and capabilities.

The minimum inside diameter at the tip of the male taper (through bore), $\emptyset f$, is not defined to accommodate the very small bore of glass syringes.

The committee acknowledges the differences in the manufacturing methodologies and the need for expanded tolerances in the glass forming manufacturing PROCESS. The baseline specifications of the tapered tip need to remain similar. However to accommodate the glass forming manufacturing PROCESS, there needs to be expanded dimensional tolerances. While these tolerances are outside of the range of this part of ISO 80369 with respect to some of the dimensions, a glass formed tip does successfully mate with the injection moulded female LUER CONNECTORS. Refer to ISO 11040-4 for a listing of those critical dimensions, their expanded corresponding tolerances and functional TEST METHODS that accommodate the formed tip manufacturing PROCESS.

A dimensional analysis of the female LUER LOCK CONNECTOR (L2), variant A thread form was conducted during the development of this part of ISO 80369 to ensure both

- proper connection to other male LUER CONNECTORS, and
- prevention of misconnection to the other CONNECTORS of the ISO 80369- series.

The analysis demonstrated that in certain instances the thread form detailed in [Figure B.6](#) and [Table B.6](#) could, if taken to certain extremes, collide with non-sealing features of the mating male LUER CONNECTOR (i.e. [Figure B.3](#) and [Figure B.4](#)) prior to a fluid tight seal being achieved. Specifically the diagonal distance between the corners of the right angle thread of the female LUER LOCK CONNECTOR of [Figure B.6](#) could bind between adjacent threads of the mating male LUER CONNECTOR. [Figure A.1](#) and [Figure A.2](#) illustrate this possible interference. This can be worsened by the allowable variations in thread profile, thread pitch and thread lead, of the features of the mating male LUER CONNECTOR. This situation is unchanged from the legacy ISO 594-2, the same magnitude of interference was possible complying CONNECTORS.

Due to the proliferation of existing LUER CONNECTORS and general lack of data indicating a problem in use, the committee determined that the same level of interference would be permitted by this part of ISO 80369 (i.e. the permissible design is unchanged).

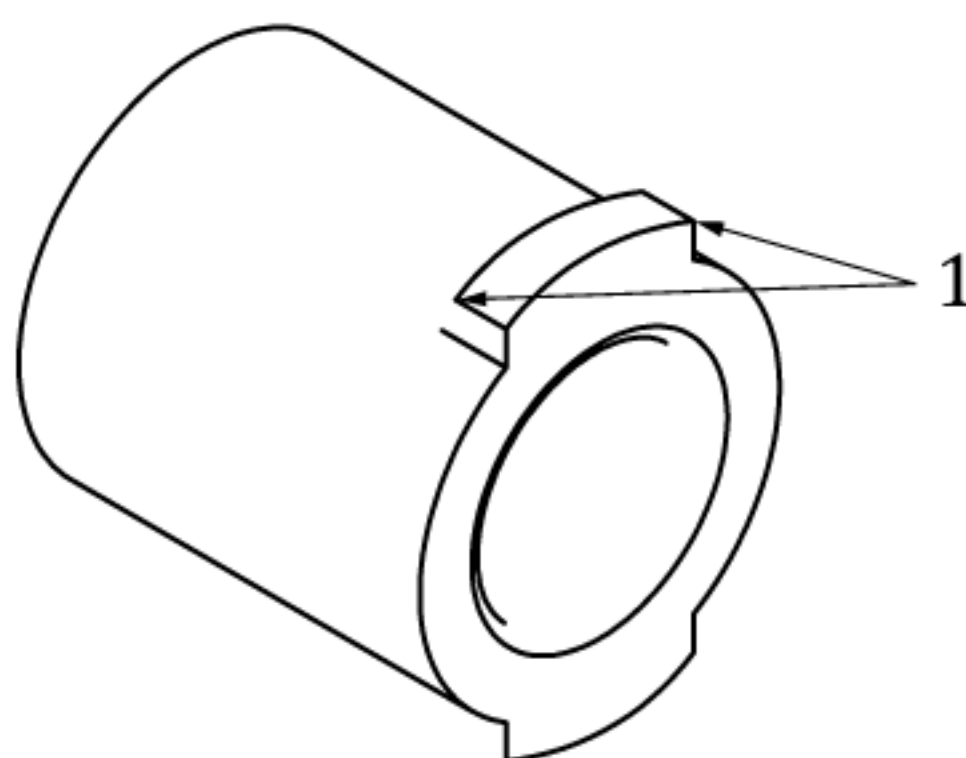

Key

- 1 corners that can interfere

Figure A.1 — Lug corners that can interfere

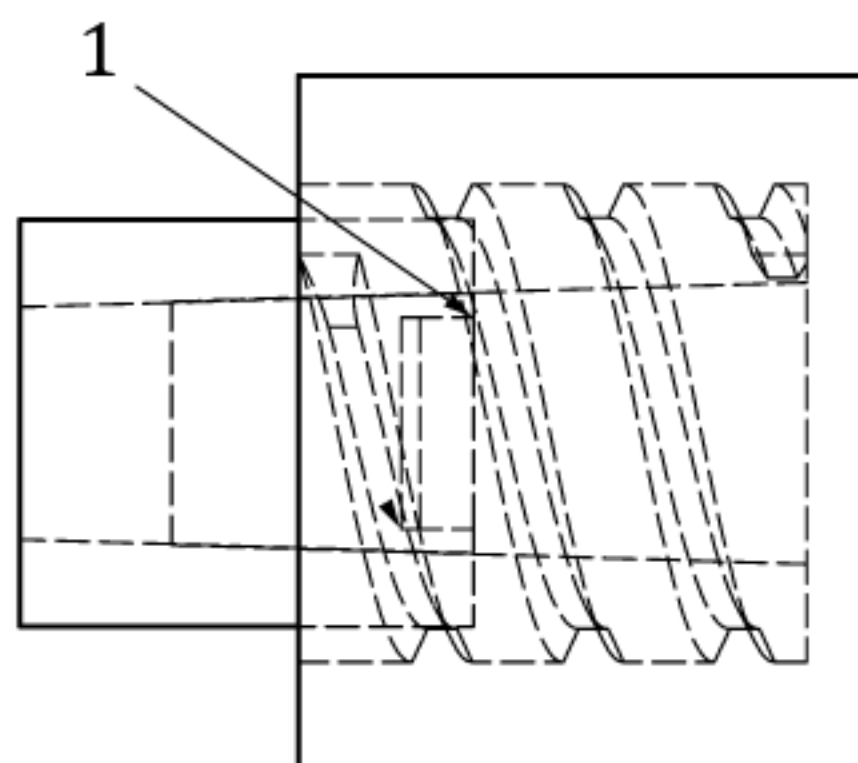

Key

1 area of potential interfere

Figure A.2 — Area of potential interference

In addition, due to the commercial evolution of existing LUER CONNECTORS, a CONNECTOR complying with ISO 594-2:1988, Figure 3, Variant A (female Luer with thread lug at right angle) was elusive to locate for testing purposes. Most participating MANUFACTURERS, who offer a “lug” version of threads, offer a version that has one side at a right angle with the other inclined at pitch “*p*”, thus these are a hybrid between the traditional ISO 594-2:1988, Figure 3, Variant A and ISO 594-2:1988, Figure 4. Since the diameters provide the features that ensure the NON-INTERCONNECTABLE characteristics are maintained, the committee decided to permit these hybrid thread lugs with the inclusion of features *N* and *N2* (width of the thread lug at the root of the leading and trailing ends, respectively).

NOTE The same levels of interference as described above (with threads at right angles) is possible within the tolerances specified. Each MANUFACTURER is encouraged to check the performance of their design to ensure the RISK of leakage is minimized.

Annex B (normative)

LUER CONNECTORS

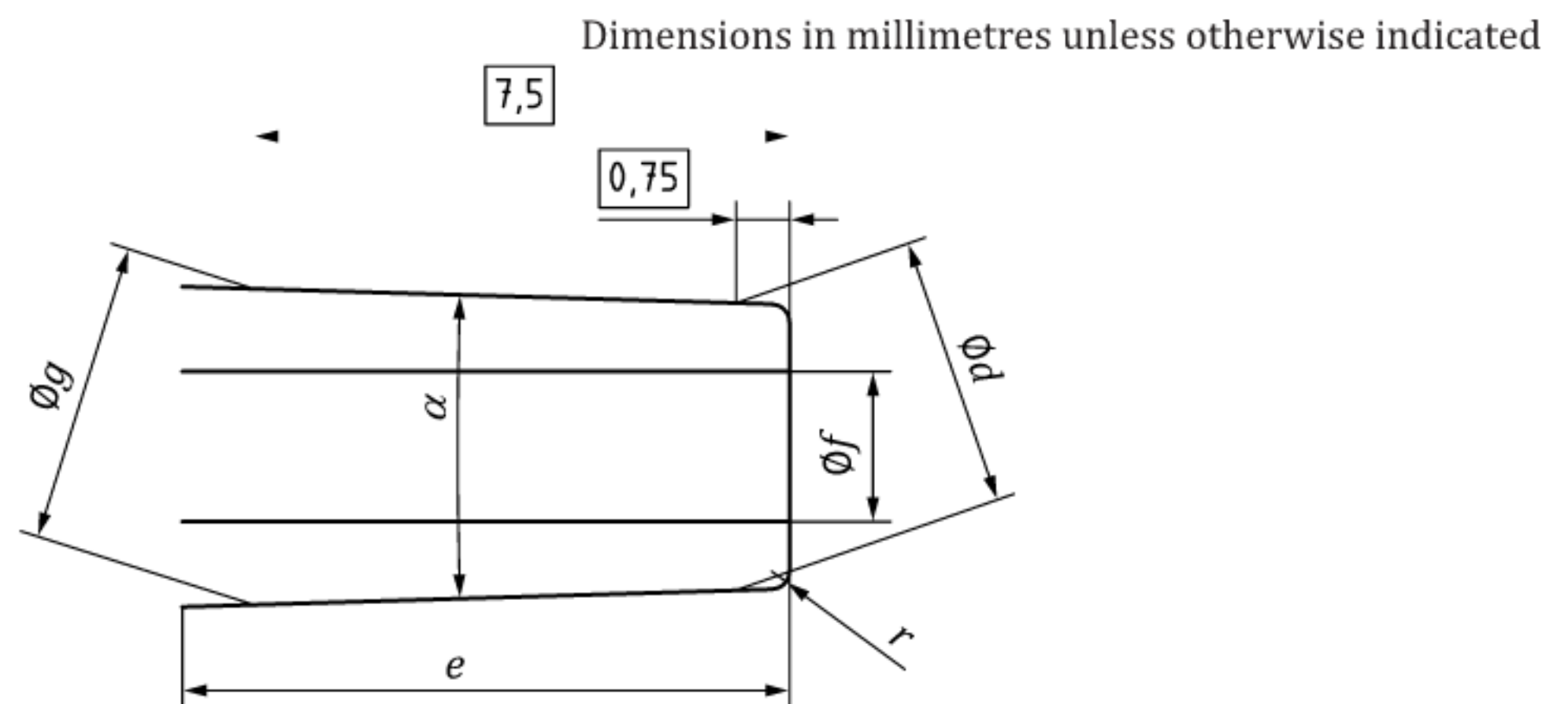

[Table B.1](#) contains the dimensions for this figure.

Figure B.1 — Male LUER SLIP CONNECTOR (L1)

Table B.1 — Male LUER SLIP CONNECTOR dimensions (L1)

Dimensions in millimetres unless otherwise indicated

Male LUER SLIP CONNECTOR (L1)				
Reference	Designation	Dimension		
		Minimum	Nominal	Maximum
(α)	Angle of the taper (6 % taper nominal) (degrees, reference)	—	(3,44°)	—
$\varnothing d$	Outside diameter at the tip of the male taper at 0,750 (basic dimension) from the tip (small end) of the male taper	3,970	4,021	4,072
e	Length of the male taper ^a	7,500	8,400	10,500
$\varnothing f$	Inside diameter at the tip of the male taper	—	2,100	2,900
$\varnothing g$	Outside diameter of the larger end of the male taper at 7,500 (basic dimension) from the tip (small end) of the male taper	4,376	4,426	4,476
r	Radius or chamfer at the outside tip of the male taper	0,000	0,250	0,500

^a This dimension also defines the extent of the CONNECTOR. MEDICAL DEVICE features beyond the CONNECTOR may require evaluation to ISO 80369-1:2010, Annex B, to ensure NON-INTERCONNECTABLE characteristics.

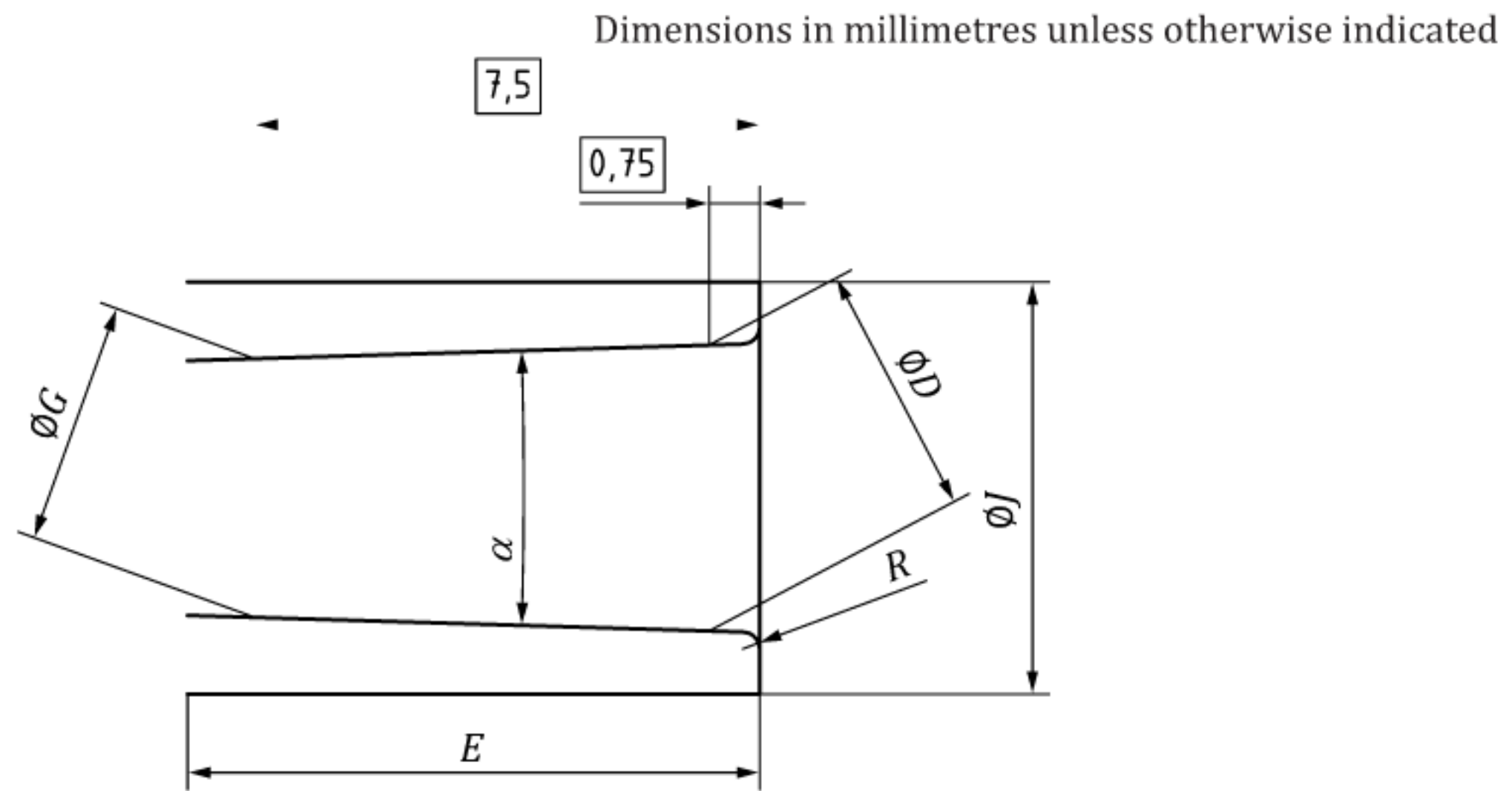

Table B.2 contains the dimensions for this figure.

Figure B.2 — Female LUER SLIP connector (L1)

Table B.2 — Female LUER SLIP CONNECTOR dimensions (L1)

Dimensions in millimetres unless otherwise indicated

Female LUER SLIP CONNECTOR (L1)				
Reference	Designation	Dimension		
		Minimum	Nominal	Maximum
α	Angle of the taper (6 % taper nominal) (degrees, reference)	—	(3,44°)	—
δD	Inside diameter at the open end of the female taper at 0,750 (basic dimension) from the opening (large end) of the female taper	4,198	4,248	4,298
E	Depth of the female taper ^a	7,500	8,400	10,500
δG	Inside diameter of the smaller end of the female taper at 7,500 (basic dimension) from the opening (large end) of the female taper	3,793	3,843	3,893
δJ	Outside diameter of the female LUER SLIP CONNECTOR of the smallest cylinder of depth of 5,5 mm from the face of the CONNECTOR that encompasses the outside surfaces of external features of the CONNECTOR	6,000	6,356	6,730
R	Radius or chamfer at the entrance of the female taper	0,000	0,250	0,500

^a This dimension also defines the extent of the CONNECTOR. MEDICAL DEVICE features beyond the CONNECTOR may require evaluation to ISO 80369-1:2010, Annex B, to ensure NON-INTERCONNECTABLE characteristics.

Dimensions in millimetres unless otherwise indicated

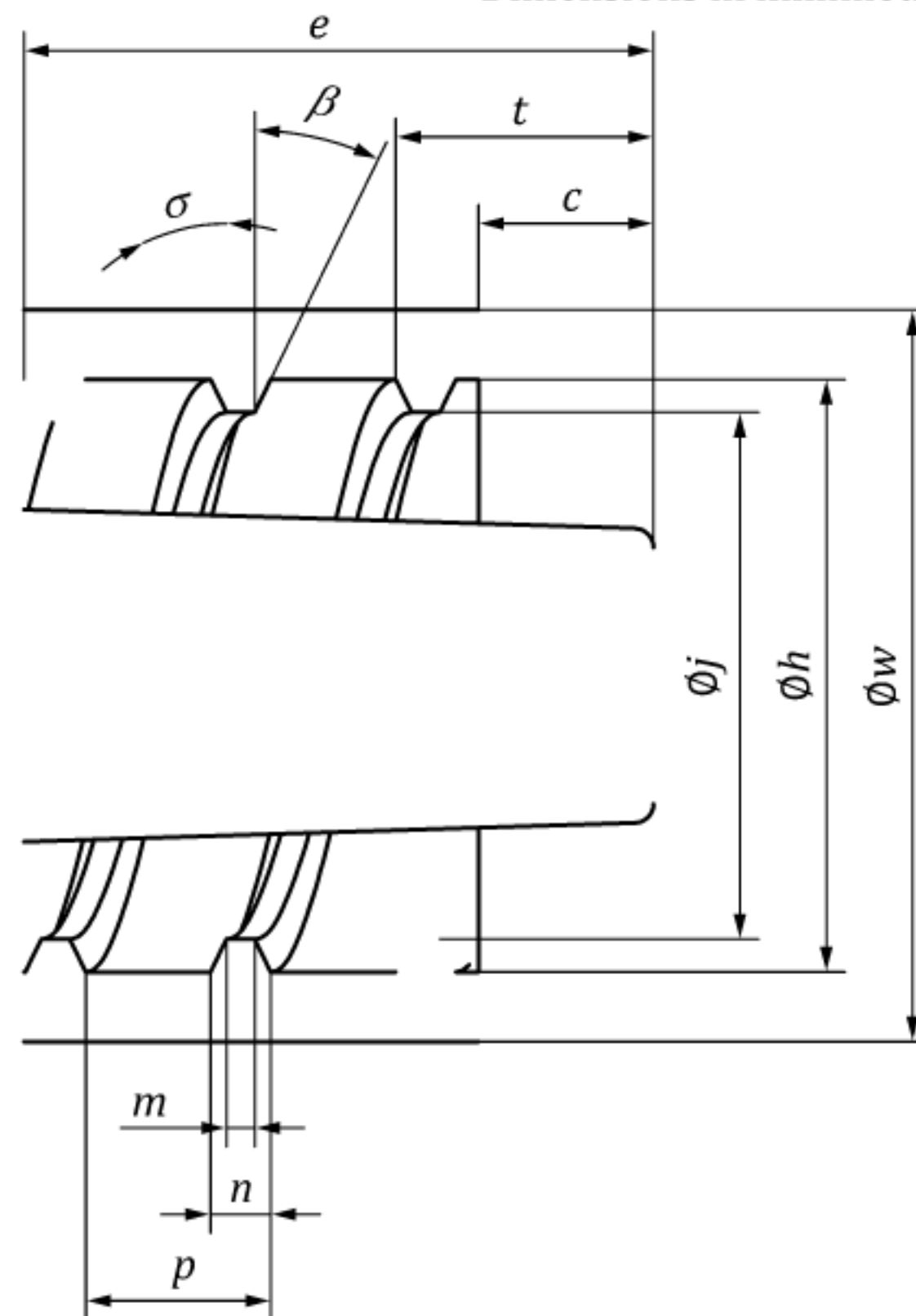

[Table B.3](#) contains the dimensions for this figure.

Figure B.3 — Male LUER LOCK CONNECTOR (L2), with fixed collar

Table B.3 — Male LUER LOCK CONNECTOR with fixed collar dimensions (L2)

Dimensions in millimetres unless otherwise indicated

Male LUER LOCK CONNECTOR (L2) with fixed collar				
Reference	Designation	Dimension		
		Minimum	Nominal	Maximum
β	Angle of internal thread profile on the non-bearing surface against separation (degrees)	25,0°	30,0°	(57,0°)
c	Projection of the tip of the CONNECTOR from the thread collar	2,100	2,150	(2,573)
e	Length of the male taper	7,500	8,400	10,500
$\varnothing h$	Major inside thread diameter (diameter at the thread root)	7,900	8,000	8,100
$\varnothing j$	Minor inside thread diameter (diameter at the thread crest)	6,800	7,000	7,200
m	Width of the thread profile at the crest	0,300	(0,326)	(0,674)
n	Width of the thread profile at the root	(0,627)	0,875	1,000
(p)	Nominal pitch of the double-start, right-hand thread (reference 5 mm lead)	—	(2,500)	—
σ	Angle of internal thread profile on the bearing surface against separation (degrees)	25,0°	27,5°	30,0°
t	Distance from the tip of the CONNECTOR to the bottom of the first complete thread profile of the internal thread	(2,727)	3,025	3,200
$\varnothing w$	Diameter of the smallest cylinder that encompasses the outside surfaces of the external features of the collar ^a	8,800	9,700	11,500

The design and dimensions of the thread profile (σ , β and m) may vary from those designated provided the CONNECTOR meets the performance requirements of [Clause 6](#).

NOTE The design and dimensions of the thread profile (σ , β and m) are not considered important to ensure NON-INTERCONNECTABLE characteristics.

The length of the thread is not specified but shall provide clearance for the thread of the female CONNECTOR.

The male LUER LOCK CONNECTOR shall include the dimensions and tolerances of the male LUER CONNECTOR as specified in [Figure B.1](#) and [Table B.1](#).

^a The specified dimensional range shall be maintained for a minimum length of 1 mm from the open end of the collar. Beyond 1 mm, the diameter may be smaller than the specified minimum. The maximum diameter specified shall be maintained for a minimum length of e . This dimension may be achieved by either the CONNECTOR or the MEDICAL DEVICE which incorporates this CONNECTOR. Alternatively, NON-INTERCONNECTABLE characteristics may be demonstrated using ISO 80369-1:2010, Annex B.

Dimensions in millimetres unless otherwise indicated

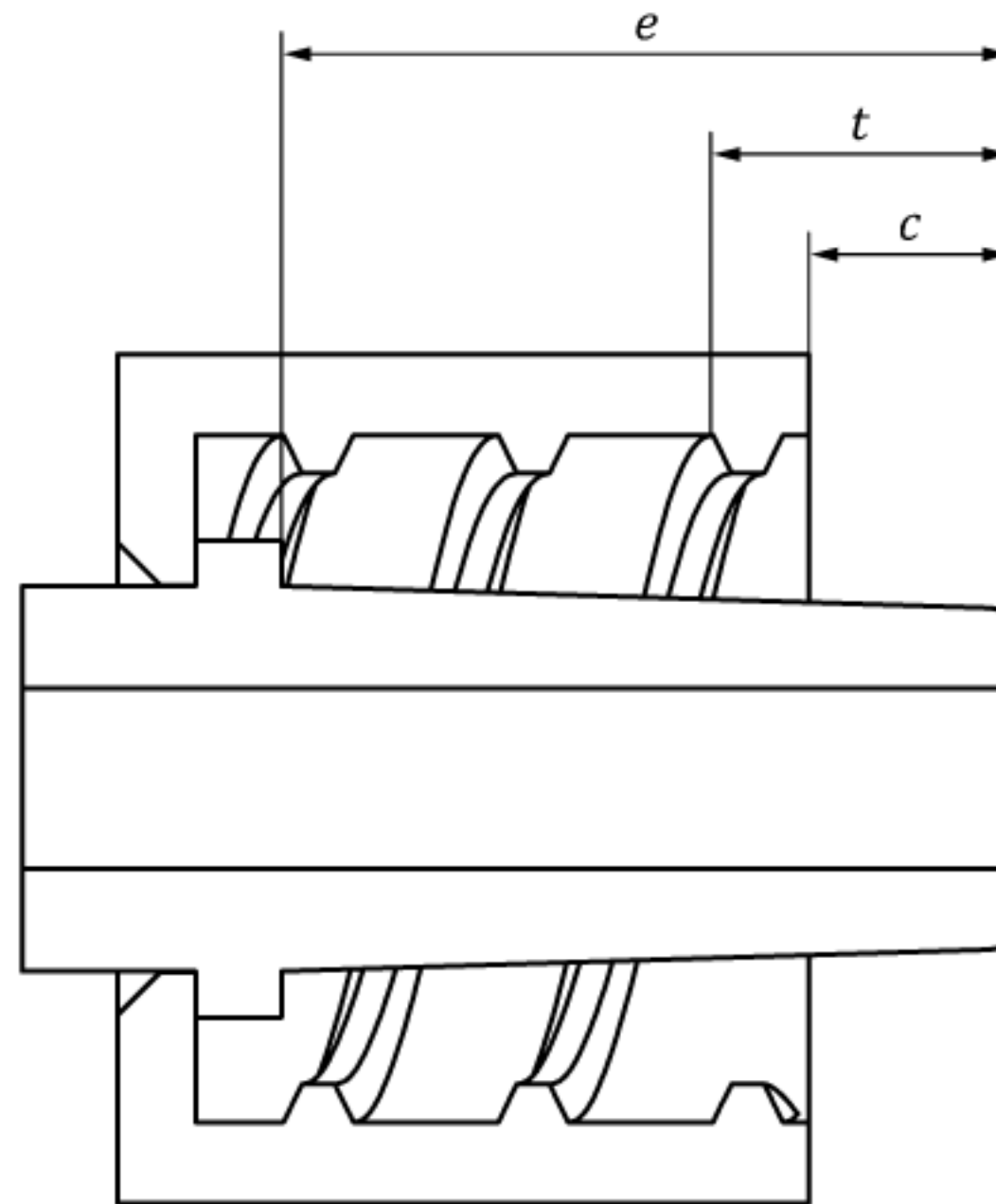

Table B.4 contains the dimensions for this figure.

Figure B.4 — Male LUER LOCK CONNECTOR (L2), with rotatable collar

Table B.4 — Male LUER LOCK CONNECTOR with a rotatable collar dimensions (L2)

Dimensions in millimetres unless otherwise indicated

Male LUER LOCK CONNECTOR (L2), with a rotatable collar				
Reference	Designation	Dimension		
		Minimum	Nominal	Maximum
c^a	Projection of the tip of the CONNECTOR from the thread collar	2,100	2,150	(2,573)
e	Length of the male taper	7,500	8,400	10,500
t^a	Distance from the tip of the CONNECTOR to the bottom of the first complete thread profile of the internal thread	(2,727)	3,150	3,200

The male LUER LOCK CONNECTOR with rotatable collar shall include the dimensions and tolerances of the male LUER CONNECTOR as specified in [Figure B.3](#) and [Table B.3](#) except as indicated in this table.

^a This dimension is when the floating or rotatable collar is positioned fully toward tip of the CONNECTOR.

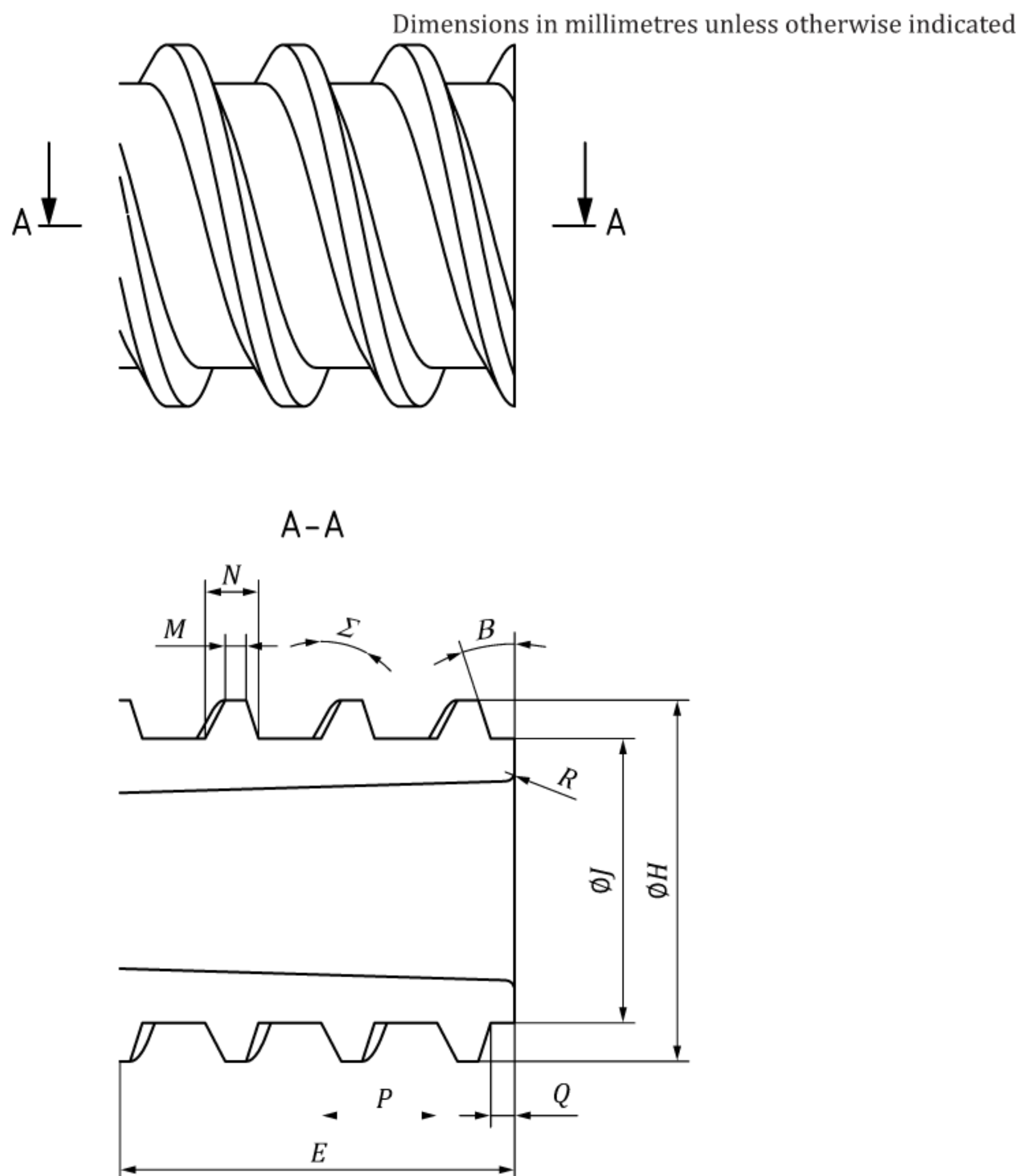

[Table B.5](#) contains the dimensions for this figure. This design and the associated dimensions shall apply to any female LUER LOCK CONNECTOR that has threads in a plane inclined to the axis of the CONNECTOR. There are no dimensional restrictions on thread length. [Figure B.6](#), [Figure B.7](#) and [Figure B.8](#) apply to designs utilizing lugs that are at a right angle to axis of the CONNECTOR.

Figure B.5 — Female LUER LOCK CONNECTOR (L2)

Table B.5 — Female LUER LOCK CONNECTOR dimensions (L2)

Dimensions in millimetres unless otherwise indicated

Female LUER LOCK CONNECTOR (L2)				
Reference	Designation	Dimension		
		Minimum	Nominal	Maximum
<i>B</i>	Angle of the external thread profile on the non-bearing surface against separation (degrees)	0,0°	15,0°	(53,0°)
<i>E</i>	Depth of the female taper	7,500	8,400	10,500
$\emptyset H$	Major outside thread diameter (diameter at thread crest) for the extent of the thread feature. This defines the diameter of the smallest cylinder of depth 5,5 mm from the face of the CONNECTOR that encompasses the outside surfaces of the external features of the CONNECTOR. This diameter shall not be increased for a distance from the hub face of 5,5 mm.	7,730	7,780	7,830
$\emptyset J$	Minor outside thread diameter (diameter at the thread root) This diameter shall not be increased for a distance from the hub face of 5,5 mm.	5,515	6,123	6,730
<i>M</i>	Width of the thread profile at the crest	0,300	(0,420)	(0,967)
<i>N</i>	Width of the thread profile at the root at a diameter corresponding to $\emptyset J$ max (6,730)	(0,533)	1,073	1,200
(<i>P</i>)	Nominal pitch of the double-start, right-hand thread (reference 5 mm lead)	—	(2,500)	—
<i>Q</i>	Distance from the face of the CONNECTOR to the base of the thread	0,000	0,200	0,300
<i>R</i>	Radius or chamfer at the entrance of the female taper	0,000	0,250	0,500
Σ	Angle of external thread profile on the bearing surface against separation (degrees)	25,0°	27,5°	30,0°
<p>The design and dimensions of the thread profile (Σ, β and <i>M</i>) may vary from those designated provided the CONNECTOR meets the performance requirements of Clause 6.</p> <p>NOTE The design and dimensions of the thread profile (Σ, β, <i>M</i> and <i>P</i>) are not considered important to ensure NON-INTERCONNECTABLE characteristics.</p> <p>The female LUER LOCK CONNECTOR shall include the dimensions and tolerances of the female LUER CONNECTOR as specified in Figure B.2 and Table B.2.</p>				

Dimensions in millimetres unless otherwise indicated

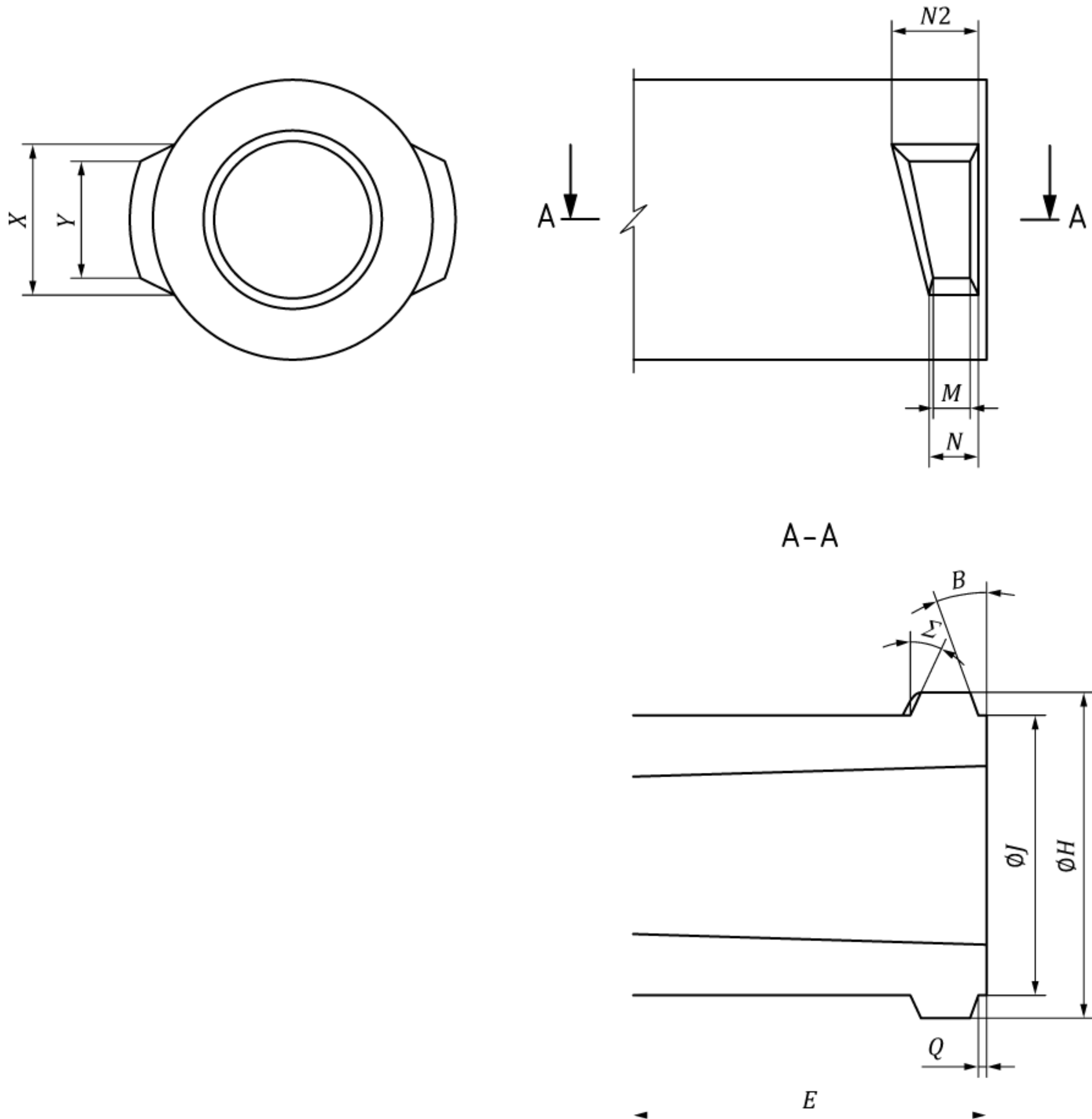

Table B.6 contains the dimensions for this figure.

Figure B.6 — Female LUER LOCK CONNECTOR with lugs at right angle to axis (L2), variant A

***Table B.6 — Female LUER LOCK CONNECTOR dimensions (L2), variant A**

Dimensions in millimetres unless otherwise indicated

Female LUER LOCK CONNECTOR (L2), variant A				
Reference	Designation	Dimension		
		Minimum	Nominal	Maximum
<i>B</i>	Angle of the external lug profile on the non-bearing surface against separation (degrees)	0,0°	15,0°	(53,0°)
<i>E</i>	Depth of the female taper	7,500	8,400	10,500
$\varnothing H$	Major outside lug diameter (diameter at the lug crest)	7,730	7,780	7,830
$\varnothing J$	Minor outside lug diameter (diameter at the lug root)	5,515	6,123	6,730
<i>M</i>	Width of the lug profile at the crest	0,300	(0,659)	(0,967)
<i>N</i>	Width of the lug profile at the root at a diameter corresponding to 6,730 on the leading end of the lug as it is screwed into a male CONNECTOR	(0,533)	1,073	1,200
<i>N2</i>	Width of the lug profile at the root at a diameter corresponding to 6,730 on the trailing end of the lug as it is screwed into a male CONNECTOR	(0,533)	1,073	2,070
<i>Q</i>	Distance from the face of the CONNECTOR to the base of the lug	0,000	0,200	0,300
Σ	Angle of external lug profile on the bearing surface against separation (degrees)	25,0°	27,5°	30,0°
<i>X</i>	Chord length at the base of the lug in a plane at a right angle to the axis of the CONNECTOR, to be measured on a chord of a circle, the diameter of which is 7,000	—	3,400	3,500
<i>Y</i>	Chord length at the extremity of the lug in a plane at a right angle to the axis of the CONNECTOR	2,710	2,810	—

The female LUER LOCK CONNECTOR with external lugs shall include the dimensions and tolerances of the female LUER CONNECTOR as specified in [Figure B.2](#) and [Table B.2](#).

Y shall not be greater than *X*.

NOTE The design and dimensions of the thread profile (Σ , β and *M*) are not considered important to ensure NON-INTERCONNECTABLE characteristics.

Dimensions in millimetres unless otherwise indicated

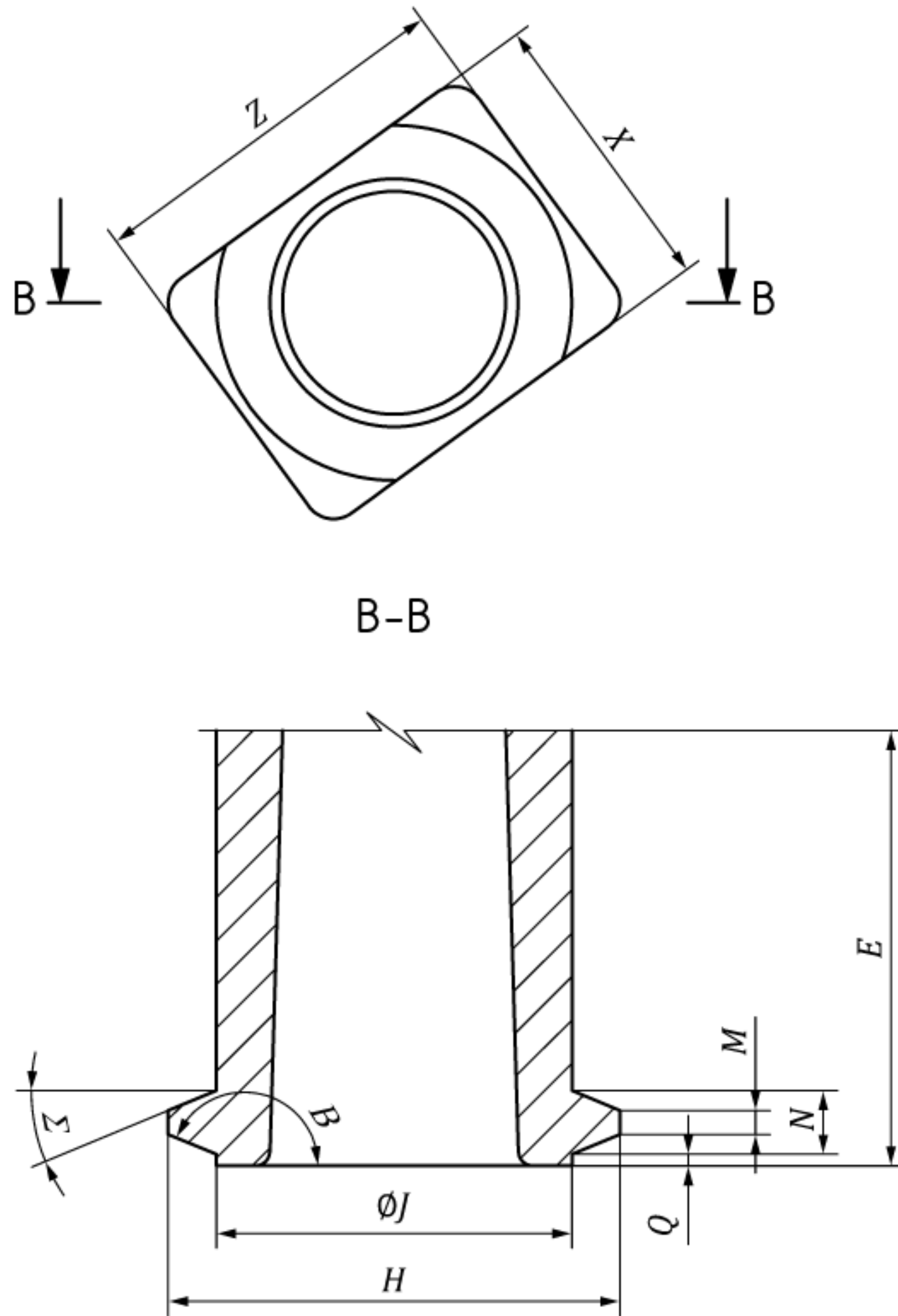

Table B.7 contains the dimensions for this figure. This variant is only intended for use in the design of RIGID MATERIAL metal CONNECTORS.

Figure B.7 — Female LUER LOCK CONNECTOR with lugs at right angle to axis (L2), variant B

Table B.7 — Female LUER LOCK CONNECTOR dimensions (L2), variant B

Dimensions in millimetres unless otherwise indicated

Female LUER LOCK CONNECTOR (L2), variant B				
Reference	Designation	Dimension		
		Minimum	Nominal	Maximum
<i>B</i>	Angle of the external lug profile on the non-bearing surface against separation (degrees)	0,0°	30,0°	(53,0°)
<i>E</i>	Depth of the female taper	7,500	8,400	10,500
$\varnothing H$	Major outside lug diameter (diameter at the lug crest)	7,700	7,750	7,800
$\varnothing J$	Minor outside lug diameter (diameter at the lug root)	5,515	5,608	5,700
<i>M</i>	Width of the lug profile at the crest	0,000	(0,240)	0,270

The female LUER LOCK CONNECTOR with external lugs shall include the dimensions and tolerances of the female LUER CONNECTOR as specified in [Figure B.2](#) and [Table B.2](#).

Table B.7 (continued)

Female LUER LOCK CONNECTOR (L2), variant B				
Reference	Designation	Dimension		
		Minimum	Nominal	Maximum
<i>N</i>	Width of the lug profile at the root at a diameter corresponding to 6,730	(0,300)	0,800	1,300
<i>Q</i>	Distance from the face of the CONNECTOR to the base of the lug	0,000	0,200	0,300
Σ	Angle of the external lug profile on the bearing surface against separation (degrees)	25,0°	27,5°	30,0°
<i>X</i>	Chord length at the base of the lug in a plane at a right angle to the axis of the CONNECTOR, to be measured on a chord of a circle, the diameter of which is 7,000	—	4,900	5,000
<i>Z</i>	Width across the lugs in a plane at a right angle to axis of the CONNECTOR	6,400	6,450	6,500

The female LUER LOCK CONNECTOR with external lugs shall include the dimensions and tolerances of the female LUER CONNECTOR as specified in [Figure B.2](#) and [Table B.2](#).

Dimensions in millimetres unless otherwise indicated

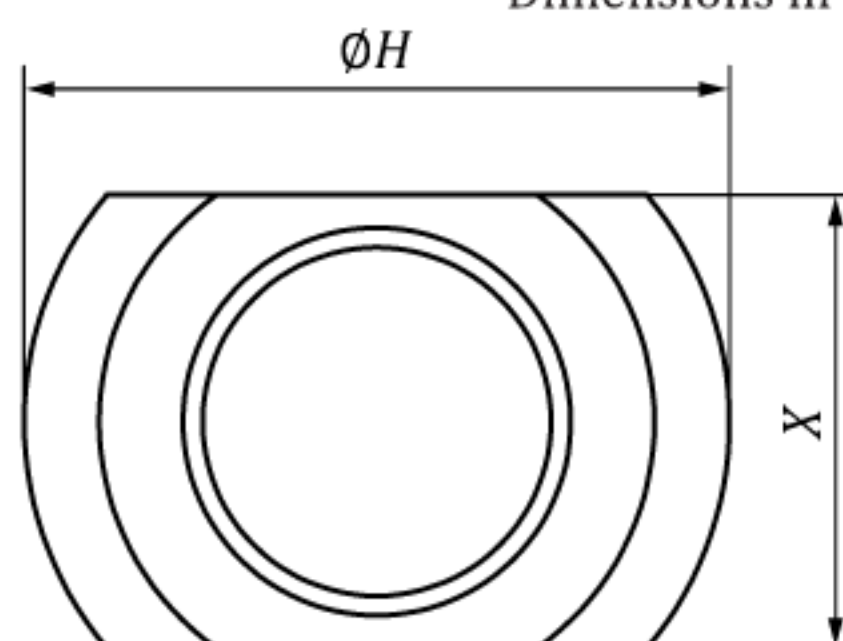

[Table B.8](#) contains the dimensions for this figure. This variant is only intended for use in the design of RIGID MATERIAL metal CONNECTORS.

Figure B.8 — Female LUER LOCK CONNECTOR with lugs at right angle to axis (L2), variant C

Table B.8 — Female LUER LOCK CONNECTOR dimensions (L2), variant C

Dimensions in millimetres unless otherwise indicated

Female LUER LOCK CONNECTOR (L2) with external threads				
Reference	Designation	Dimension		
		Minimum	Nominal	Maximum
$\varnothing H$	Major outside lug diameter (diameter at the lug crest)	7,700	7,750	7,800
<i>X</i>	Chord length at the base of the lug in a plane at a right angle to the axis of the CONNECTOR, to be measured on a chord of a circle, the diameter of which is 7,000	—	4,900	5,000

The female LUER LOCK CONNECTOR with external lugs shall include the dimensions and tolerances of the female LUER CONNECTOR as specified in [Figure B.2](#) and [Table B.2](#) as well as Section B-B of [Figure B.7](#) and [Table B.7](#).

Annex C
(normative)

Reference CONNECTORS

C.1 General requirements for reference CONNECTORS

Reference CONNECTORS shall be manufactured from corrosion-resistant RIGID MATERIALS with a surface roughness value, Ra, not exceeding 0,8 μm on critical surfaces.

C.2 Reference CONNECTORS

Dimensions in millimetres unless otherwise indicated

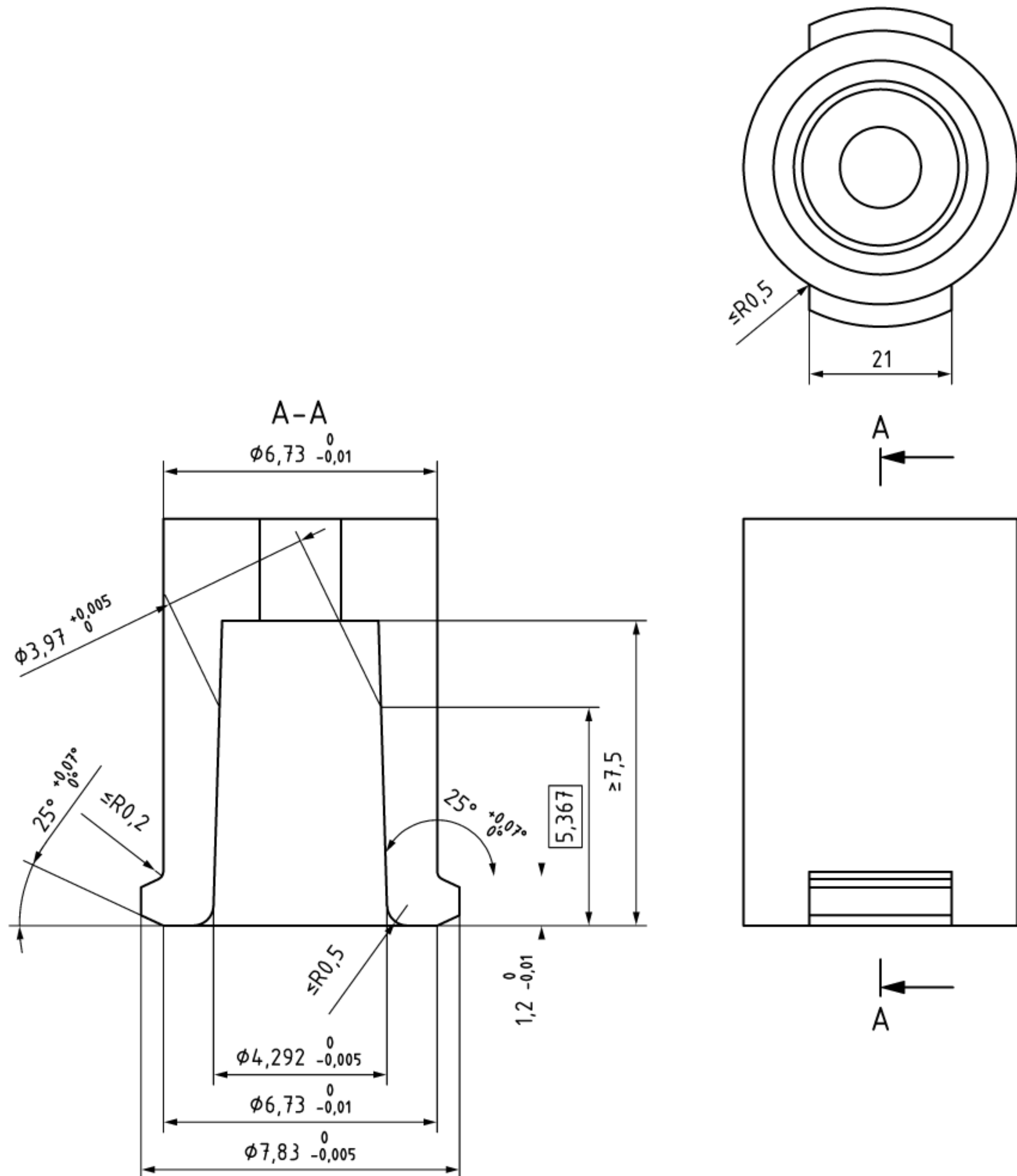

In [Figure C.1](#), all outside edges of lug or thread form shall have a radius between 0,15 mm and 0,20 mm (unless otherwise specified). *R* may be $\times 45^\circ$ chamfer.

Figure C.1 — Female reference LUER LOCK CONNECTOR for testing male LUER CONNECTORS for leakage, separation from unscrewing, stress cracking and NON-INTERCONNECTABLE characteristics

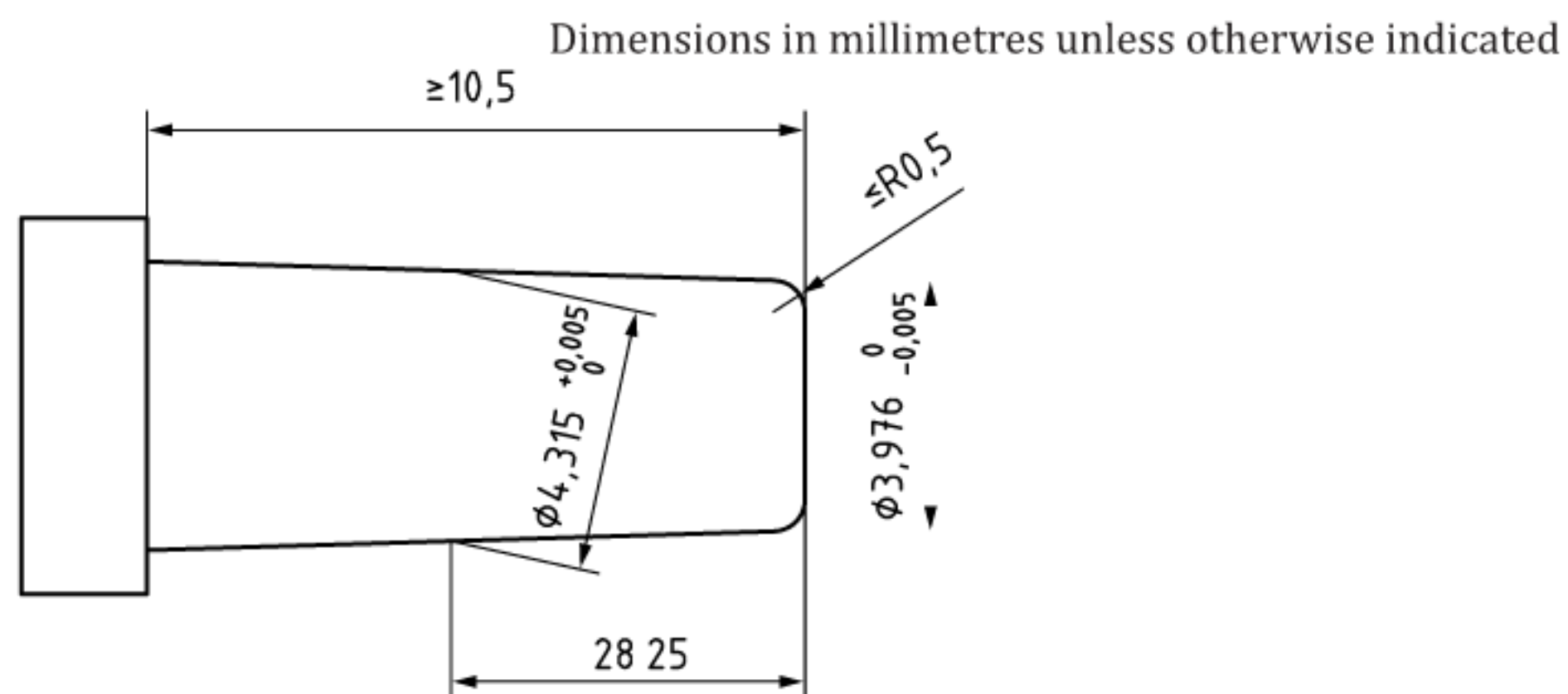

NOTE 1 Cone taper (0,06:1).

NOTE 2 R may be 0,5 mm (maximum) \times 45° chamfer. The minimum length of the male taper of 10,5 mm is required for testing NON-INTERCONNECTABLE characteristics. A minimum length of the male taper of 7,5 mm may be used for the performance tests of [Clause 6](#).

Figure C.2 — Male reference LUER SLIP CONNECTOR for testing female LUER CONNECTORS for leakage, separation from axial load, stress cracking and NON-INTERCONNECTABLE characteristics

Dimensions in millimetres unless otherwise indicated

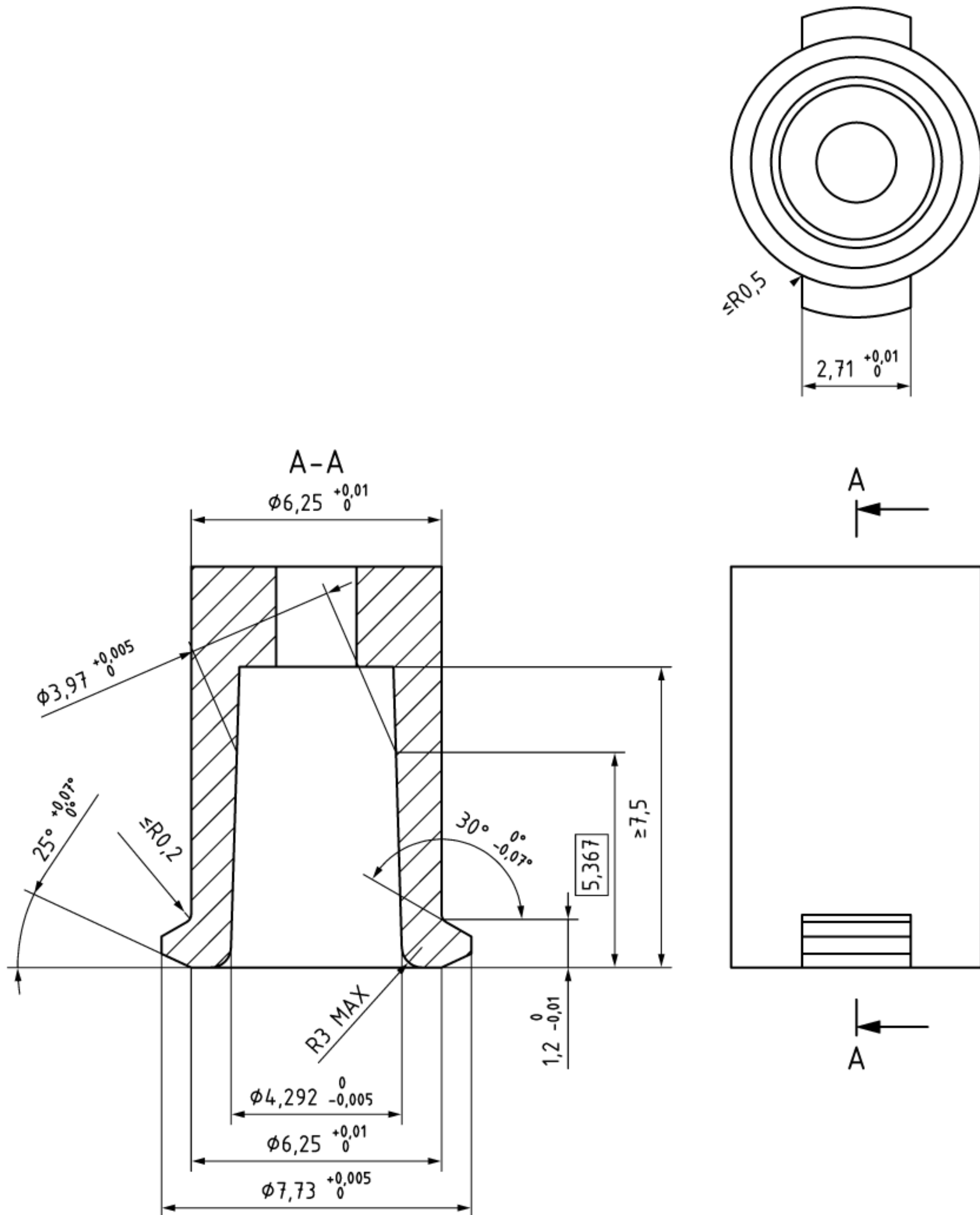

In [Figure C.3](#), all outside edges of lug or thread form shall have a radius between 0,15 mm and 0,20 mm (unless otherwise specified). *R* may be $\times 45^\circ$ chamfer.

Figure C.3 — Female reference CONNECTOR for testing male LUER LOCK CONNECTOR for separation from axial load and resistance to overriding

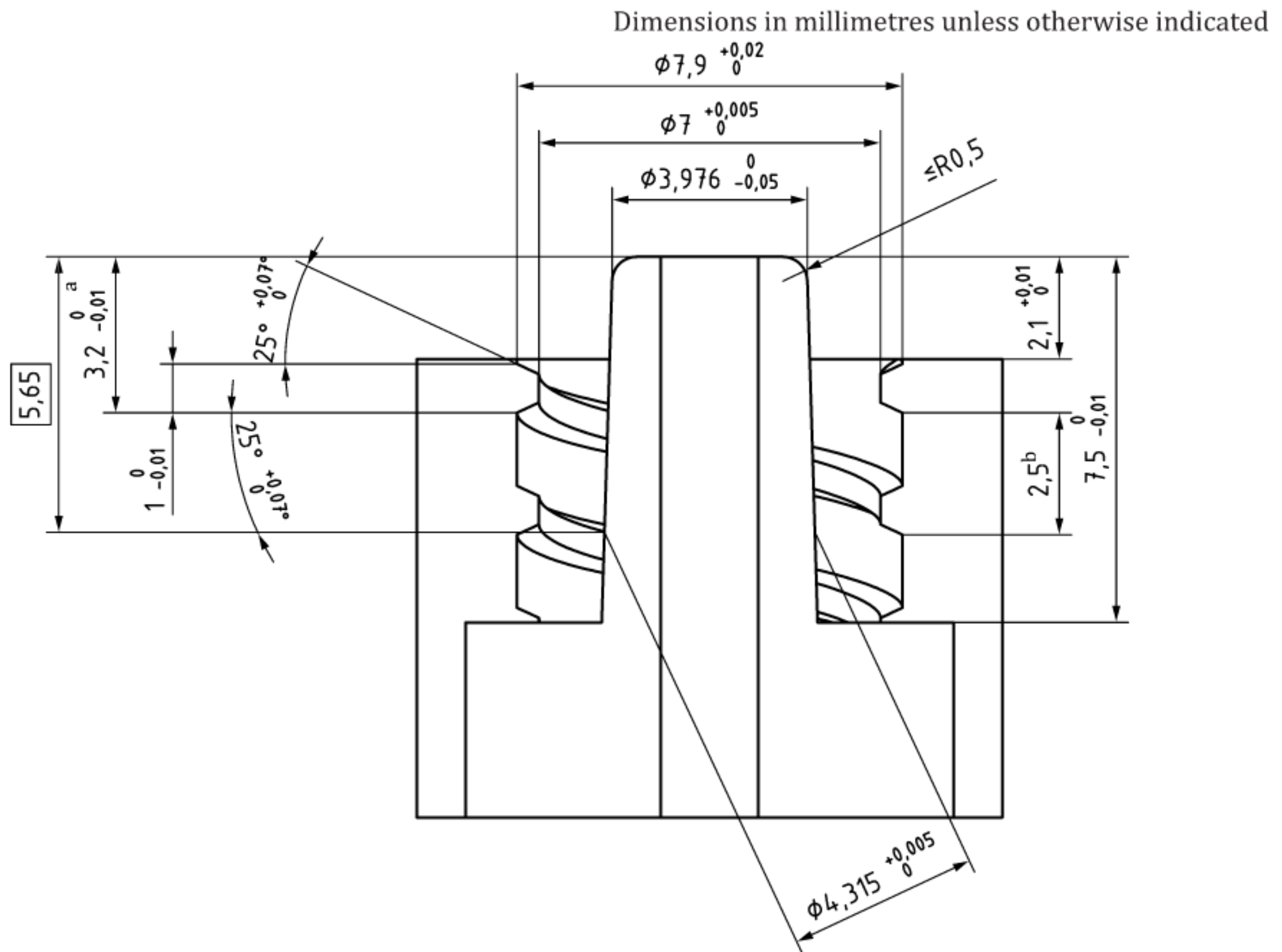

- a Maximum distance from tip of male LUER LOCK CONNECTOR to the first complete profile of the internal thread (see [Table B.3](#), dimension *t*).
- b Double-start, right-hand thread of 2,5 mm pitch.

NOTE *R* may be 0,5 mm (maximum) × 45° chamfer.

Figure C.4 — Male reference LUER LOCK CONNECTOR for testing female LUER CONNECTORS for leakage, separation from unscrewing, stress cracking and NON-INTERCONNECTABLE characteristics

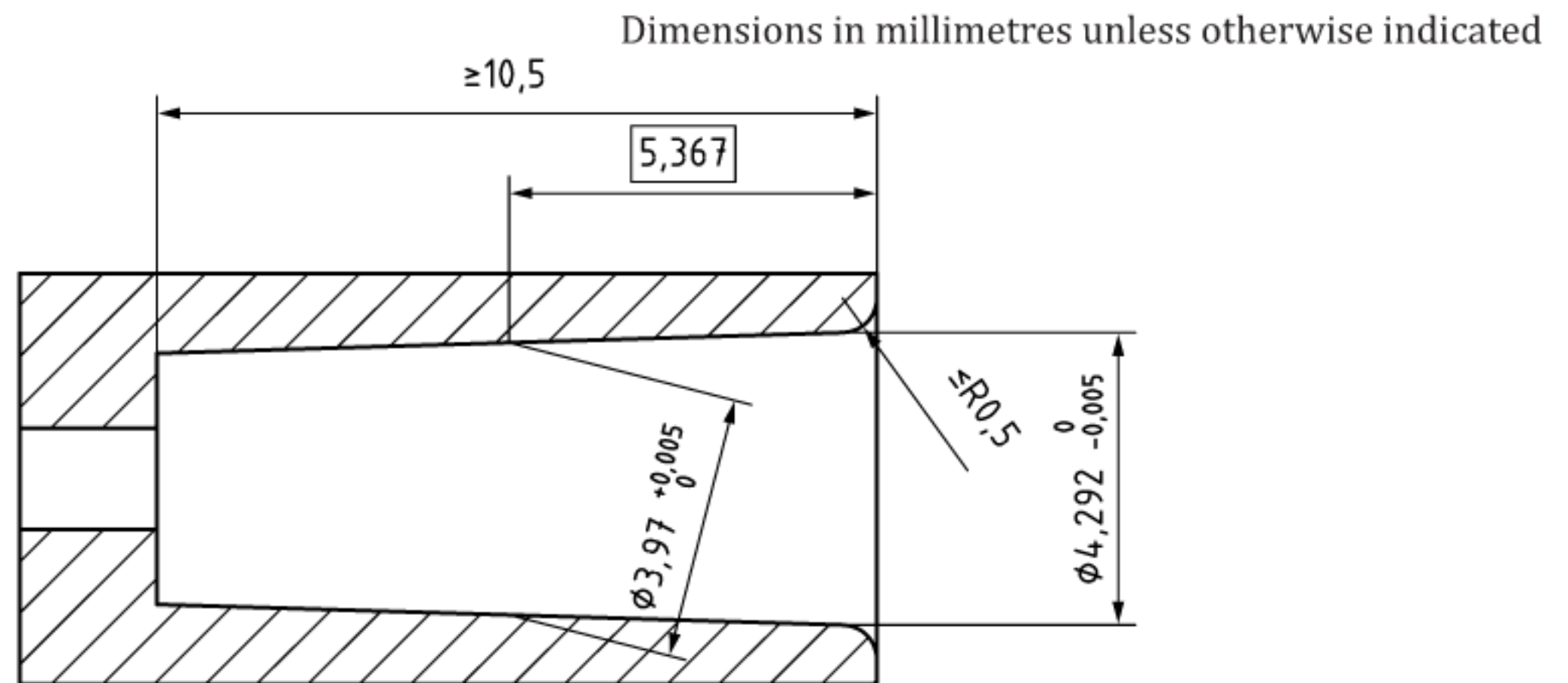

NOTE 1 Cone taper (0,06:1).

NOTE 2 R may be 0,5 mm (maximum) \times 45° chamfer. The minimum length of the male taper of 10,5 mm is required for testing NON-INTERCONNECTABLE characteristics. A minimum length of the male taper of 7,5 mm may be used for the performance tests of [Clause 6](#).

Figure C.5 — Female reference LUER SLIP CONNECTOR for testing male LUER CONNECTORS for leakage, separation from axial load, stress cracking and NON-INTERCONNECTABLE characteristics

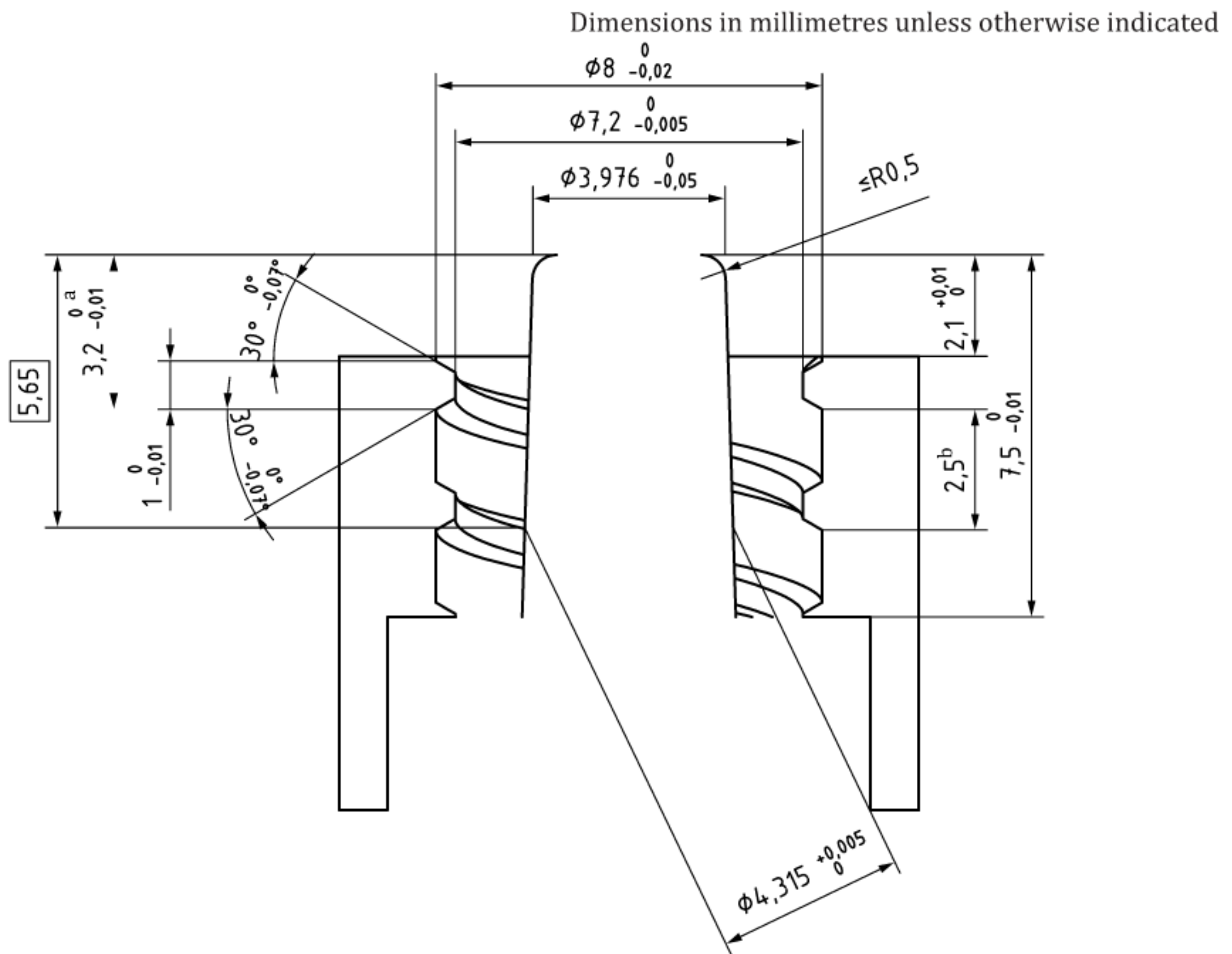

- a Maximum distance from tip of male LUER LOCK CONNECTOR to the first complete profile of the internal thread (see [Table B.3](#), dimension *t*).
- b Double-start, right-hand thread of 2,5 mm pitch.

NOTE *R* may be 0,5 mm (maximum) × 45° chamfer.

Figure C.6 — Male reference CONNECTOR for testing female LUER LOCK CONNECTOR for separation from axial load and resistance to overriding

Annex D (informative)

Assessment of MEDICAL DEVICES and their attributes with CONNECTIONS within this APPLICATION

[Table D.1](#) contains examples of MEDICAL DEVICES and ACCESSORIES within intravascular or hypodermic APPLICATIONS. The table contains an assessment by the working group of the important attributes of MEDICAL DEVICES and ACCESSORIES as they relate to the intended CONNECTION. Each CONNECTION is assessed according to the following index or subgroups:

- a) syringe CONNECTIONS;
- b) needle CONNECTIONS;
- c) IV tubing set CONNECTIONS;
- d) IV tubing set port CONNECTIONS;
- e) retention mechanism (e.g. balloon) CONNECTIONS used to hold invasive MEDICAL DEVICES in place;
- f) IV catheter CONNECTIONS;
- g) IV catheter port CONNECTIONS;
- h) stopcock CONNECTIONS;
- i) adaptor CONNECTIONS;
- j) medication compounding adaptor CONNECTIONS.

Table D.1 — Examples of MEDICAL DEVICES with CONNECTIONS within this APPLICATION and their attributes

Part/component to which the CONNECTION is applied	Index	Flowrate range ml/min	Type of fluid		Type of CONNECTION		Therapy disruption	PATIENT haemorrhage from fluid loss	Disrupted sample collection	Infection control	Functionality		
			Air	Liquid	Connection	Dis-CONNECTION					Locking needed	Slip needed	Flowrate control needed
Syringe	1	0 to 1 200	yes	yes	yes	yes	yes	no	yes	yes	yes	yes	yes
Needle	2	0 to 1 200	yes	yes	yes	yes	yes	yes	yes	yes	yes	yes	yes
IV tubing set	3	0 to 1 200	yes	yes	yes	yes	yes	yes	yes	yes	yes	yes	yes
IV tubing set port	4	0 to 1 200	yes	yes	yes	yes	yes	yes	no	yes	yes	yes	yes
Retention mechanism (e.g. balloon) CONNECTIONS used to hold invasive MEDICAL DEVICES in place	5	0 to 1 200	yes	yes	yes	yes	yes	no	no	no	yes	yes	yes
IV catheter	6	0 to 1 200	yes	yes	yes	yes	yes	yes	yes	yes	yes	yes	yes
IV catheter port	7	0 to 1 200	yes	yes	yes	yes	yes	yes	yes	yes	yes	yes	yes
Stopcock	8	0 to 1 200	yes	yes	yes	yes	yes	yes	no	yes	yes	yes	yes
Adaptor	9	0 to 1 200	yes	yes	yes	yes	yes	yes	yes	yes	yes	yes	yes
Medication compounding adaptor	10	0 to 1 200	yes	yes	yes	yes	yes	no	no	yes	yes	yes	yes

Annex E (informative)

Summary of the usability requirements for LUER CONNECTORS for intravascular or hypodermic APPLICATIONS

E.1 USER PROFILE

The USER PROFILE is a summary of the mental, physical and demographic traits of an intended USER population, as well as any special characteristics that can have a bearing on design decisions, such as occupational skills and job requirements.

USERS of LUER CONNECTORS for intravascular or hypodermic APPLICATIONS are comprised of the clinical, laboratory, or non-clinical persons using, i.e. operating or handling, the MEDICAL DEVICE, including, but not limited to, cleaners, maintainers and installers, PATIENTS, or other laypersons. USERS are expected to perform an intended action in an INTENDED USE of a MEDICAL DEVICE, ACCESSORY, PROCESS or service in accordance with the specifications, instructions and information provided by the MANUFACTURER.

USERS include the following:

- a) clinical USERS, such as
 - 1) physicians who specialize in anaesthesiology, neuro-radiology, paediatrics, oncology, haematology/nursing, emergency room, medicine, interventional radiology, or as a physician assistant,
 - 2) nurses, at all levels, including Certified Registered Nurse Anaesthetist (CRNA) etc.,
 - 3) emergency medical technicians, and
 - 4) homecare providers, visiting nurses, relatives;
- b) non-clinical USERS, such as cleaners, maintainers and installers;
- c) *in vitro* diagnostics laboratory and pharmacy USERS, responsible for mixing of drugs, filling syringes and reservoirs, storage and dispensing of drugs.

The USER PROFILE is summarized in [Table E.1](#).

Table E.1 — USER PROFILE

	PATIENTS AS USERS	Clinical USERS	Non-clinical USERS	<i>in vitro</i> diagnostic laboratory and pharmacy USERS
USER skills:	No training	Extensive clinical training	Limited clinical training	Bioengineers, central processing
PATIENT contact:	Direct PATIENT contact	Direct PATIENT contact	Direct PATIENT contact	No PATIENT contact

E.2 Use scenarios

Use scenarios for LUER CONNECTORS for intravascular or hypodermic APPLICATIONS can differ by USER group, and are comprised of the multitude of sub-APPLICATIONS of the CONNECTORS within different sub-specialities.

A summary of use scenarios by USER group is summarized in [Table E.2](#).

Table E.2 — Use scenarios

Subspecialty use scenario	PATIENTS as USERS	Clinical USERS	Non-clinical USERS	<i>in vitro</i> diagnostic laboratory and pharmacy USERS
1. Parenteral				
— Chemo	X	X	X	X
— Insulin, subcutaneous	X	X	X	—
— Infusion, IV catheter placements	—	X	X	X
— Medication preparation	X	X	X	X
— Injections	X	X	X	X
— Parenteral nutrition, including TPN (Total parenteral nutrition)	X	X	X	X
2. Extracorporeal				
— Dialysis	—	—	—	—
— Peritoneal Dialysis	X	X	X	X
— Haemodialysis	X	X	X	—
— ECMO (extracorporeal membrane oxygenation)	—	X	—	—
— Invasive pressure monitoring	—	X	—	—
— ICP Intracranial pressure	—	X	—	—
— IABP Intra-aortic balloon pump	—	X	—	—
— VAD Ventricular assist device	—	X	—	—
— Cardio-pulmonary bypass	—	X	—	—
— Cardiac catheters	—	X	—	—
— Rapid infusers	—	X	—	—
— Radiological marker pressure infusers	—	X	—	X
3. Irrigation				
— Wound care	X	X	X	—
— Aspiration	X	X	X	—
— Sample collection	X	X	X	—
4. Retention mechanism (e.g. balloon) (both gas or liquids)				
— Foley catheters	X	X	X	—
— Rectal catheters	X	X	X	—
— PEGs	X	X	X	—
— Tracheal tubes	—	X	—	—
— Laryngeal Mask Airways	—	X	—	—
— Tracheostomy tubes	X	X	X	—
5. Ports				
— Subdermal	X	X	X	X
— Pain management	X	X	X	X
— Gastric Lapbands	X	X	X	—
— Implant inflation	—	X	X	—
6. Blood				
— Sample collection	X	X	X	X
— Transfusion	X	X	X	—

Table E.2 (continued)

Subspecialty use scenario	PATIENTS as USERS	Clinical USERS	Non-clinical USERS	<i>in vitro</i> diagnostic laboratory and pharmacy USERS
— Donation/Phlebotomy	X	X	X	—
7. Medication preparation				
— Add-mixture	X	X	X	X
— Compounding	X	X	X	X
8. Other				
— Thermodilution catheters	—	X	—	—

E.3 Use environments

E.3.1 Facilities

Hospitals, surgery suites, PATIENT rooms, home, labour and delivery, intensive care units, doctors' offices, pain clinics, pharmacy, field hospitals, transport systems, infusion clinics, home assisted care, emergency medical services.

E.3.2 Use temperature

The following temperature environments are expected for LUER CONNECTORS:

- ambient temperature, -40 °C to $+60\text{ °C}$ (for field use in emergency medical services);
- body temperature, to 42 °C ;
- hypothermia treatment, 10 °C (for therapeutic cooling of spinal cord injuries);
- hypo/normo/hyperthermia treatments, 10 °C to 43 °C (for ECMO treatments).

E.4 Other attributes

The following other attributes are expected for LUER CONNECTORS:

- usability under stress (ignoring labels, attempting force-fit);
- proximity of liquids, use of gloves;
- proximity of other CONNECTOR-bearing equipment (e.g. sphygmomanometers, gas measurement).

E.5 Generic USER needs

The following USER needs attributes are expected for LUER CONNECTORS:

- minimal pan-healthcare USER training on the use of CONNECTORS;
- easy to manipulate without the use of tools;
- ease of assembly/disassembly with finger-tip control, especially in wet environment or with the use of gloves;
- does not misconnect to other SMALL-BORE CONNECTORS not intended for the same purpose in the environment of use (ISO 80369-1);
- does not leak under NORMAL USE;

- f) security/integrity of CONNECTION, cannot unintentionally self-disconnect;
- g) low dead space;
- h) ease of fluid passage
 - 1) rate limiting factors;
 - 2) maximum flowrate
 - i) cardiovascular equipment, diluted blood: 4 l/min, at 3 bar with a dynamic viscosity of 6,89 mPa/s to prevent haemolysis,
 - ii) dialysis equipment, blood: 600 ml/min at 400 mmHg below atmospheric pressure, and
 - iii) IV pump, aqueous solutions: 1 200 ml/min at 300 mmHg pressure;
 - 3) Viscosity of solutions
 - i) aqueous,
 - ii) chemotherapy,
 - iii) steroids, and
 - iv) hyperbaric local anaesthetics;
- i) needle-through-needle techniques, needle stylets (guide wires, peripheral catheters, etc.);

NOTE Lumen diameter requirements are MEDICAL DEVICE specific and can require a MEDICAL DEVICE-specific RISK ASSESSMENT to provide for different capabilities.
- j) compatible with disinfection, decontamination, sterilization, reprocessing environments;
- k) LUER SLIP CONNECTORS are required to address several USER needs, such as
 - 1) need to align the syringe with the 3-way stopcock,
 - 2) need to prevent movement of needle orientation during CONNECTION,
 - 3) cognitive distinction between LUER SLIP CONNECTORS and LUER LOCK CONNECTORS to prevent a misperception that the LUER SLIP CONNECTOR is locked,
 - 4) lightweight and unobtrusive needle hub,
 - 5) little additional cost (making/purchasing), and
 - 6) consider the need for visible fluid paths in specific MEDICAL DEVICES.

Annex F (informative)

Summary of LUER CONNECTOR design requirements for intravascular or hypodermic APPLICATIONS

[Table F.1](#) is a summary of the design requirements for LUER CONNECTORS for intravascular or hypodermic APPLICATIONS.

Table F.1 — LUER CONNECTOR specific design requirements for intravascular or hypodermic APPLICATIONS

	Criteria		Requirements	Remarks
1	Fluid type	a) Liquid b) Gas c) Both	c)	—
2	Operating pressure range	maximum pressure minimum pressure sub-atmospheric? (yes/no)	300 kPa Yes, 80 kPa	—
3	RATED pressure range	minimum maximum	See Item 2	—
4	Is there a need for a leak test?	a) No b) Yes Reference for TEST METHOD	b)	—
5	RATED flowrate range	minimum maximum	0 ml/min 1 200 ml/min	—
6	Internal diameter range (through bore)	minimum maximum	0 mm 2,9 mm	—
7	RATED temperature range	minimum maximum	-40 °C 60 °C	—
8	Minimum range of CONNECTOR mating diameters	minimum maximum	—	Not compatible with other new SMALL- BORE CONNECTORS
9	General layout	a) Parallel-sided, O-ring seal b) Parallel-sided, other seal c) Conical d) Other (specify)	c) d)	—
10	Method of keying	a) Collar b) Plug c) Other (specify)	none	—
11	Quick release?	a) No b) Yes i) single-handed operation ii) double-handed operation	a)	—
12	Positive locking/locking feature?	a) No b) Yes	b)	—
13	Need for visual indication of locking status?	a) No b) Yes	a)	—
14	Need for indication of evidence of tampering?	a) No b) Yes	a)	—

Table F.1 (continued)

	Criteria		Requirements	Remarks
15	Need for a syringe in the APPLICATION?	a) No b) Yes	b)	—
16	Need for an absence of sharp edges?	a) No b) Yes	b)	—
17	Minimum axial force in NORMAL USE, to remain attached	force Reference for TEST METHOD	23 N LUER SLIP CONNECTOR 32 N LUER LOCK CONNECTOR ISO 594-1 ISO 594-2	—
18	Constructional materials (excluding seals)	a) RIGID MATERIAL i) metal ii) plastic b) SEMI-RIGID MATERIAL	a) i) or ii) b) > 700 MPa	—
19	Need for use of SEMI-RIGID MATERIAL?	a) No b) Yes, mating part of CONNECTOR (apart from seal)	a) or b)	—
20	MRI compatibility?	a) No, with labelling b) No, without labelling c) Yes, with labelling d) Yes, without labelling	b) or d)	—
21	Stress-cracking resistance?	a) No b) Yes Specify limits	b)	—
22	Externally, how is CONNECTOR to be distinguishable from LUER CONNECTOR? (describe)		Not applicable	This is the LUER CONNECTOR
23	Proposal for colour-coding?	a) No b) Yes Reference standard	a)	—
24	Labelling/Symbols/Marking?	a) No (e.g. not for IV) b) Yes	a)	—
25	Other method for indicating INTENDED USE?	a) No b) Yes Indicate method	a)	—
26	Biocompatibility considered?	a) No b) Yes	b)	—
27	Reuse variants	a) Multiple PATIENT use b) Single PATIENT use c) Single use d) Non-reusable (indicate method of auto-disabling)	a) b) or c)	—
28	Decontamination needed?	a) No, single use only b) Yes, cleaning and disinfection; indicate method c) Yes, cleaning and sterilization; indicate method	a) b) or e.g. isopropyl alcohol c)	—
29	How is ISO 80369-2 incompatibility achieved?	a) Dimensional b) Other Indicate method	a)	—

Table F.1 (continued)

	Criteria		Requirements	Remarks
30	How is ISO 80369-3 incompatibility achieved?	a) Dimensional b) Other Indicate method	a)	—
31	How is IEC 80369-5 incompatibility achieved?	a) Dimensional b) Other Indicate method	a)	—
32	How is ISO 80369-6 incompatibility achieved?	a) Dimensional b) Other Indicate method	a) b)	N1 male misconnection possible; see G.2.2 .
33	How is ISO 80369-7 incompatibility achieved? (ISO 594-1 and ISO 594-2)	a) Dimensional b) Other Indicate method	This is a LUER CONNECTOR.	—

Annex G (informative)

Summary of assessment of the design of the LUER CONNECTOR for intravascular or hypodermic APPLICATIONS

G.1 General

CONNECTORS that comply with this part of ISO 80369 were designed and manufactured under the same essential design and dimensional requirements as those that comply with the previous International Standards^[4].

CONNECTORS represented by these standards have been successfully manufactured as components to MEDICAL DEVICES for over 100 years.

G.2 Summary of the engineering analysis of the design

G.2.1 NON-INTERCONNECTABLE ANALYSIS

A three-dimensional computer aided design (CAD) engineering analysis has been performed using computational analysis and 3D solid model constructs of all tolerances and material conditions (least, nominal and maximum) for all CONNECTORS represented by the ISO 80369- series. The SMALL-BORE CONNECTORS specified in this part of ISO 80369 have been shown by engineering analysis to be NON-INTERCONNECTABLE with the other specified CONNECTORS of the ISO 80369- series with the exception of the following. [Table G.1](#) summarizes the potential misconnections.

A technical report is planned to describe the PROCESS for the CAD engineering analysis more completely.

Table G.1 — Summary of possible misconnection from CAD analysis

LUER CONNECTOR	CONNECTOR of concern	Summary	Reference
male	N1 male	Misconnection possible	G.2.2
female slip	E1 female	Physical testing according ISO 80369-1:2010, Annex B, (except using all plastic parts) results in no CONNECTION	G.2.3
female slip	N2 male lock	Physical testing according ISO 80369-1:2010, Annex B, results in no CONNECTION	G.2.4
E1 from ISO 80369-3:2016.			
N2 from ISO 80369-6:2016.			

G.2.2 LUER CONNECTOR male to N1 male

In the engineering analysis, the inside diameter of the fluid lumen of male LUER CONNECTOR contacts the sealing surfaces of the N1 male CONNECTOR, as specified in ISO 80369-6:2016, in LMC conditions and thereby these CONNECTORS will mutually fail the NON-INTERCONNECTABLE characteristics tests of ISO 80369-1:2010, Annex B. [Figure G.1](#) illustrates this misconnection.

Testing was performed according to the TEST METHOD of ISO 80369-6:2016, Annex H. The CONNECTION did not leak and thereby these CONNECTORS mutually fail this NON-INTERCONNECTABLE characteristics test. Both of these CONNECTORS are distal to the PATIENT in clinical use in the PATIENT vicinity. In this environment, this misconnection would connect an infusion source to an infusion source, which is not

hazardous to the PATIENT. In the pharmacy, this misconnection could allow cross filling of vascular and neuraxial medications.

This misconnection is judged to be an acceptable RISK.

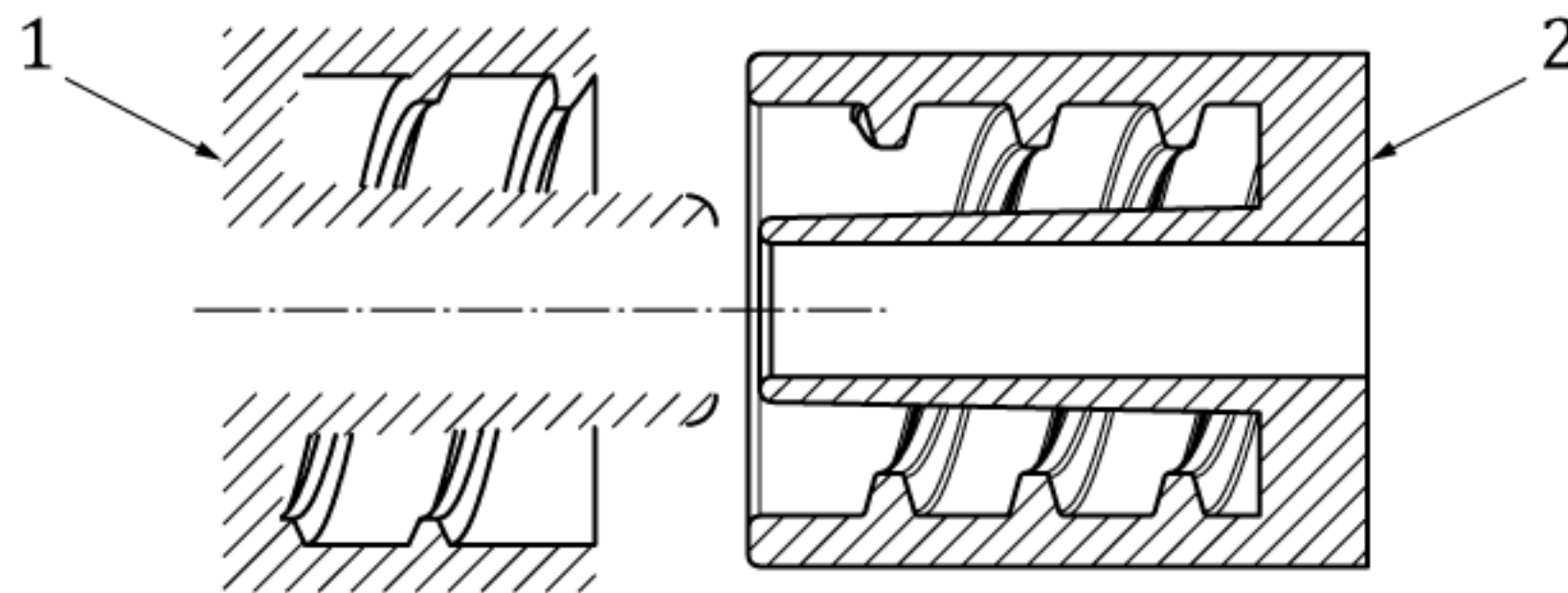

Key

- 1 male LUER CONNECTOR
- 2 male N1

Figure G.1 — Illustration LUER CONNECTOR male to N1 male misconnection

G.2.3 LUER SLIP CONNECTOR female to E1 female

Testing was performed according to the TEST METHOD of ISO 80369-1:2010, Annex B, while substituting CONNECTORS of least material condition (LMC) and worst-case flexural modulus material (700 MPa to 720 MPa) for both the reference LUER SLIP CONNECTOR female and the E1 CONNECTOR being evaluated. The committee considers this modification of the TEST METHOD to be more conservative.

The test demonstrated that the CONNECTORS are NON-INTERCONNECTABLE.

G.2.4 LUER SLIP CONNECTOR female to N2 male lock

Testing was performed according to the TEST METHOD of ISO 80369-1:2010, Annex B.

The test demonstrated that the CONNECTORS are NON-INTERCONNECTABLE.

G.3 Summary of the design VERIFICATION

See [G.1](#) and [G.2](#).

Because of the long and successful history of widespread clinical use, the committee concluded that it was unnecessary to evaluate further these CONNECTOR systems according to PROCESSES and PROCEDURES of ISO 80369-1:2010, Clause 7. That notwithstanding, performance testing was conducted on test articles that were available in the marketplace at the time and included components made from the following materials.

LUER CONNECTORS from two softer polymers are

- CONNECTORS made from two polypropylenes (PP) having a nominal modulus of elasticity (tensile) of 700 MPa, and 950 MPa.

LUER CONNECTORS from three harder polymers are

- CONNECTORS made from styrene acrylonitrile (SAN) having a nominal modulus of elasticity (tensile) of 3 800 MPa,
- CONNECTORS made from acrylonitrile butadiene styrene (ABS) having a nominal modulus of elasticity (tensile) of 2 400 MPa, and

ISO 80369-7:2016(E)

- CONNECTORS made from polycarbonate (PC) having a nominal modulus of elasticity (tensile) of 2 344 MPa.

LUER CONNECTORS from two metals are

- CONNECTORS made from brass and stainless steel.

This range of modulus spans the available common materials most often used in intravascular and hypodermic APPLICATIONS and meets the requirements of [4.2](#).

Performance testing was conducted according to ISO 80369-20:2015 as required by [Clause 6](#) using 60 samples per test group.

Conclusion:

The performance test results indicate that LUER CONNECTOR design is compliant with the performance requirements as specified in [Clause 6](#) using the TEST METHODS defined in ISO 80369-20:2015.

G.4 Summary of the design validation

See [G.1](#) and [G.2](#).

The LUER CONNECTOR of this part of ISO 80369 is generally the same design as the current CONNECTOR design of ISO 594.

The current CONNECTOR design has been in use for IV CONNECTIONS in clinical settings since 1930. The intended use of the ISO 594 Luer for intravenous and hypodermic CONNECTIONS is the same intended use as the LUER CONNECTORS of this part of ISO 80369.

The SMALL-BORE CONNECTORS as defined in ISO 80369-6 have been tested in a human factors study (as described in ISO 80369-6:2016, G.4), which demonstrated that the misconnection potential between the male LUER CONNECTOR and male N1 CONNECTOR of ISO 80369-6 has been reduced to as low as reasonable practicable.

These studies, along with the CAD validation activities ([G.2](#)), ensure that the misconnection potential has been reduced to as low as reasonable practicable to acceptable levels with the LUER CONNECTOR design of this part of ISO 80369.

Additionally, the clinical workflow for the ISO 594 CONNECTORS and the LUER CONNECTOR design of this part of ISO 80369 does not change; therefore, no further usability study is needed for the LUER CONNECTOR design of this part of ISO 80369.

G.5 Summary of the design review

LUER CONNECTORS, which conform to this part of ISO 80369, also conform to the previous Luer standards, ISO 594-1 and ISO 594-2.

The committee reviewed the assessment of the design of the LUER CONNECTORS based on the results reported in this Annex.

In summary, the design review concludes there is significant objective engineering, technical and clinical evidence supporting the LUER CONNECTOR for the intended APPLICATION.

Annex H (informative)

Reference to the essential principles

This part of ISO 80369 has been prepared to support the essential principles of safety and performance of SMALL-BORE CONNECTORS intended to be used for CONNECTIONS in intravascular or hypodermic APPLICATIONS of MEDICAL DEVICES and related ACCESSORIES according to ISO 16142-1:2016. This part of ISO 80369 is intended to be acceptable for conformity assessment purposes.

Compliance with this part of ISO 80369 provides one means of demonstrating conformance with the specific essential principles of ISO 16142-1:2016. Other means are possible. [Table H.1](#) maps the clauses and subclauses of this part of ISO 80369 with the essential principles of ISO 16142-1:2016.

Table H.1 — Correspondence between this part of ISO 80369 and the essential principles

Essential principle of ISO 16142-1:2016	Corresponding clause(s)/ subclause(s) of this part of ISO 80369	Qualifying remarks/ Notes
8.5	Clause 4 , Clause 5 , Clause 6	This Essential Principle is partially covered by ensuring that the connector does not leak and can only be connected to intended MEDICAL DEVICES OR ACCESSORIES
12.1	Clause 4 , Clause 5 , Clause 6	—
17.4	Clause 4 , Clause 5 , Clause 6	—
17.5	Clause 4 , Clause 5 , Clause 6	—

Annex I (informative)

Terminology — Alphabetized index of defined terms

NOTE The ISO Online Browsing Platform (OBP) provides access to terms and definitions.¹⁾

Term	Source
ACCESSORY	ISO 80369-1:2010, 3.1
APPLICATION	ISO 80369-1:2010, 3.2
CONNECTION	ISO 80369-1:2010, 3.4
CONNECTOR	ISO 80369-1:2010, 3.5
HARM	ISO 14971:2007, 2.2
INTENDED USE	ISO 14971:2007, 2.5
LUER CONNECTOR	3.1
LUER SLIP CONNECTOR	3.2
LUER LOCK CONNECTOR	3.3
MANUFACTURER	ISO 14971:2007, 2.8
MEDICAL DEVICE	ISO 14971:2007, 2.9
NON-INTERCONNECTABLE	ISO 80369-1:2010, 3.6
NORMAL USE	3.4
PATIENT	ISO 80369-1:2010, 3.7
PROCEDURE	ISO 14971:2007, 2.12
PROCESS	ISO 14971:2007, 2.13
RATED	3.5
RESPONSIBLE ORGANIZATION	ISO 80369-1:2010, 3.8
RIGID MATERIAL	ISO 80369-1:2010, 3.9
RISK	ISO 14971:2007, 2.16
RISK ASSESSMENT	ISO 14971:2007, 2.18
SEMI-RIGID MATERIAL	ISO 80369-1:2010, 3.10
SMALL-BORE	ISO 80369-1:2010, 3.11
TEST METHOD	ISO 80369-20:2015, 3.1
TYPE TEST	ISO 80369-20:2015, 3.2
USER	3.6
USER PROFILE	3.7
VERIFICATION (VERIFIED)	ISO 14971:2007, 2.28

1) Available at: <https://www.iso.org/obp/ui/#home>

Bibliography

- [1] ISO 178, *Plastics — Determination of flexural properties*
- [2] ISO 527-2, *Plastics — Determination of tensile properties — Part 2: Test conditions for moulding and extrusion plastics*
- [3] ISO 594-1:1986, *Luer conical fittings with a 6 % (Luer) taper for syringes, needles and certain other medical equipment — Part 1: General requirements*
- [4] ISO 594-2:1998, *Luer conical fittings with a 6 % (Luer) taper for syringes, needles and certain other medical equipment — Part 1: Luer lock fittings*
- [5] ISO 3040:1990, *Technical drawings— Dimensioning and tolerancing — Cones²⁾*
- [6] ISO 5356-1:2004, *Anaesthetic and respiratory equipment — Conical connectors — Part 1: Cones and socket³⁾*
- [7] ISO 5356-1:2015, *Anaesthetic and respiratory equipment — Conical connectors — Part 1: Cones and sockets*
- [8] ISO 5356-2:2006, *Anaesthetic and respiratory equipment — Conical connectors — Part 2: Screw-threaded weight-bearing connectors⁴⁾*
- [9] ISO 5356-2:2012, *Anaesthetic and respiratory equipment — Conical connectors — Part 2: Screw-threaded weight-bearing connectors*
- [10] ISO 8185:2007, *Respiratory tract humidifiers for medical use — Particular requirements for respiratory humidification systems*
- [11] ISO 8536-4, *Infusion equipment for medical use — Part 4: Infusion sets for single use, gravity feed*
- [12] ISO 8537, *Sterile single-use syringes, with or without needle, for insulin*
- [13] ISO 8638, *Cardiovascular implants and extracorporeal systems — Extracorporeal blood circuit for haemodialysers, haemodiafilters and haemofilters*
- [14] ISO 3040:2009, *Geometrical product specifications (GPS) — Dimensioning and tolerancing — Cones⁵⁾*
- [15] ISO 10241-1, *Terminological entries in standards — Part 1: General requirements and examples of presentation*
- [16] ISO 10241-2, *Terminological entries in standards — Part 2: Adoption of standardized terminological entries*
- [17] ISO 11040-4, *Prefilled syringes — Part 4: Glass barrels for injectables and sterilized subassembled syringes ready for filling*
- [18] ISO 14971:2007, *Medical devices — Application of risk management to medical devices*
- [19] ISO 16142-1:2016, *Medical devices — Recognized essential principles of safety and performance of medical devices — Part 1: General essential principles and additional specific essential principles for all non-IVD medical devices and guidance on the selection of standards*

2) Withdrawn.

3) Withdrawn.

4) Withdrawn.

5) Withdrawn.

- [20] ISO 80369-2:—⁶⁾, *Small-bore connectors for liquids and gases in healthcare applications — Part 2: Connectors for breathing systems and driving gases applications*
- [21] ISO 80369-3:2016, *Small-bore connectors for liquids and gases in healthcare applications — Part 3: Connectors for enteral applications*
- [22] IEC 60601-1:2005+AMD1:2012, *Medical electrical equipment - Part 1: General requirements for basic safety and essential performance*
- [23] IEC 60601-1-11:2015, *Medical electrical equipment — Part 1-11: General requirements for basic safety and essential performance — Collateral standard: Requirements for medical electrical equipment and medical electrical systems used in the home healthcare environment*
- [24] IEC 60601-1-12:2014, *Medical electrical equipment — Part 1-12: General requirements for basic safety and essential performance — Collateral Standard: Requirements for medical electrical equipment and medical electrical systems intended for use in the emergency medical services environment*
- [25] IEC 62366-1:2015, *Medical devices — Part 1: Application of usability engineering to medical devices*
- [26] IEC 80369-5, *Small-bore connectors for liquids and gases in healthcare applications -- Part 5: Connectors for limb cuff inflation applications*
- [27] CEN/CR 13825, *Luer connectors — A report to CEN CHeF from the CEN forum task group “Luer fittings”*
- [28] EN 13544-2:2002, *Respiratory therapy equipment — Part 2: Tubing and connectors*
- [29] EN 13544-2:2002+Amd1:2009, *Respiratory therapy equipment — Tubing and connectors*

6) Under development.

www.iso.org

